



misterstep

GAMIA METAL

ISTRUZIONI DI POSA

ASSEMBLY INSTRUCTIONS

INSTRUCTIONS DE MONTAGE

INSTRUCCIONES PARA LA COLOCACION

MONTAGEANLEITUNG

INSTRUÇÕES DE INSTALAÇÃO

English

Description

Modular spiral staircase in metal, with round section and adjustable spacers

Number of steps and “floor-to-floor” height

11 + 1 steps : 2520-2760 mm (8 3 1/4” - 9 0”)

12 + 1 steps : 2730-2990 mm (8 11 1/2” - 9 9 3/4”)

13 + 1 steps : 2940-3220 mm (9 7 3/4” - 10 6 3/4”)

Steps

Of stamped plate, with adhesive non-slippery strips

Risers

Standard Min 210 mm (8 1/4”); Max 230 mm (9”) (for risers 200 ÷ 210 mm (7 7/8” ÷ 8 1/4”); 230 ÷ 240 mm (9” ÷ 9 1/2”) it is possible to cut the balusters during the assembly)

Railing

With metal steel tubing balusters Ø 22 mm (7/8”) (clear space among the balusters < 100 mm, 4”).
Flexible plastic handrail (handrail height = 1000 mm, 39 3/8”)

Finishes and colours

Metal: plastic coated.

Plastic componentes, rubber matting and screws: black.

Kit

- a) Packing with 11 complete simple steps Ø 1200, 1400, 1600 mm (47 1/4”, 55 1/8”, 63”)
- b) Packing with complete landing platform Ø 1250, 1450, 1650 mm (49 1/4”, 57 1/8”, 65”)
- c) Packing with one simple extra step Ø 1200, 1400, 1600 mm (47 1/4”, 55 1/8”, 63”)
- d) Packing balustrade 1000 mm (39 3/8”) long section (handrail apart)
- e) Packing “safety-riser” for 11 steps

NOTES FOR INSTALLATION

Before starting to install the stair:

- ***check well all staircase well dimension;***
- ***make sure that in the installation area there are no pipes or power cables to prevent damaging these;***
- ***check the bearing capacity of the pavement.***

1) Assemble the pole in the sequence indicated, locking the elements firmly together, levering using a pin in the holes in the tubes.

2) Position the post with reference to the opening, arranging the landing step on the exit side of the stair. Before securing the platform, make sure of its perfect horizontality by the use of the level tube. Before taking the measure of the holes in the floor for the center pole, block temporarily the platform on the pole to avoid traveling and measurement errors. In the case of wooden floor/slab use only screws for wood, of the hanger bolt/leg bolt type, to replace those provided exclusively suited to reinforced concrete.

3) Regulate the plastic spacers adjusting the ring nut, leaving between the two edges a distance equivalent to: Riser – 170 mm (6 11/16”). It is necessary to give a half turn more to the flange of all plastic spacers, so as to increase the average height and recover the tolerances of the threading when you compact the stair. Attention: in the first rise, from the average height of the plastic spacer must be deducted the thickness of the central pole plate.

- 4) Insert the elements in the post beginning from the plate cover, going on with spacers and steps and finishing with the landing.
- 5) Position the landing step according to the opening. In the case of wooden floor/slab use only screws for wood, of the hanger bolt/leg bolt type, to replace those provided exclusively suited to reinforced concrete.
- 6) Insert the terminal flange, the threaded bar and the terminal in the pole, then tighten using the nut, in order to compress the staircase, but leaving the steps free to rotate.
- 7) Put together the pipe fitting "Novia" assembling the elements. For the assembly of plastic components of the railing always use the lubricating grease.
- 8) Insert balusters in all steps, doweling the ones that go through the step and locking the other ones with the expansion bushing "Espa". Lock well the plastic insert in the outer bush of plastic, before inserting it in the baluster. be careful not to overtighten the screw. check it before inserting the column into the hole Do not fully tighten all the fixing dowels of the passing balusters before having compacted the whole stair. Finish the definitive tightening only after having completely screwed the threaded rod with a M22 nut.
- 9) The first baluster of the stair need to be cut and secured to the floor with pipe fitting "Bicchierino". In the case of wooden floor/slab use only screws for wood, of the hanger bolt/leg bolt type, to replace those provided exclusively suited to reinforced concrete.

10) Balusters ajustement

Before baluster's tightening it is necessary to adjust the slope according to the risers.

11) This draw shows the assembling of "Safety-riser" for model Gamia Wood. The same instructions are for model Gamia Metal. If the safety riser baluster is too long, you need to resize it to measure

12) Having completed the staircase assembly, apply the supplied adhesive non-slippery strips

13) Assembling of landing balustrade

For the platform railing, in correspondence of the passing hole use the baluster 1165 mm long that is specially provided in the kit, to be cut to size. Fix the provided baluster-floor fixing element to block the last passing baluster on the landing platform (on the opposite side of the platform railing) or the last baluster of the platform railing.

The handrail of the stair must be fixed first to the passing balusters and secondly to the central balusters of the step.

14) Balusters assembling

- Assemble the balusters (Ht. 925 mm, 36 3/8") connecting the bushing "Espa" and screwing the fitting
- Mark out the floor the central position of the balusters for the balustrade, note also that a distance of about 50 mm (2") from the opening is needed and that the axle base among the balusters can't be over 120 mm (4 1/2")
- Drill holes with a \varnothing 12 mm (1/2"94) bit and insert the nylon expanders.
- In the case of wooden floor/slab use only screws for wood, of the hanger bolt / leg bolt type, to replace those provided exclusively suited to reinforced concrete.

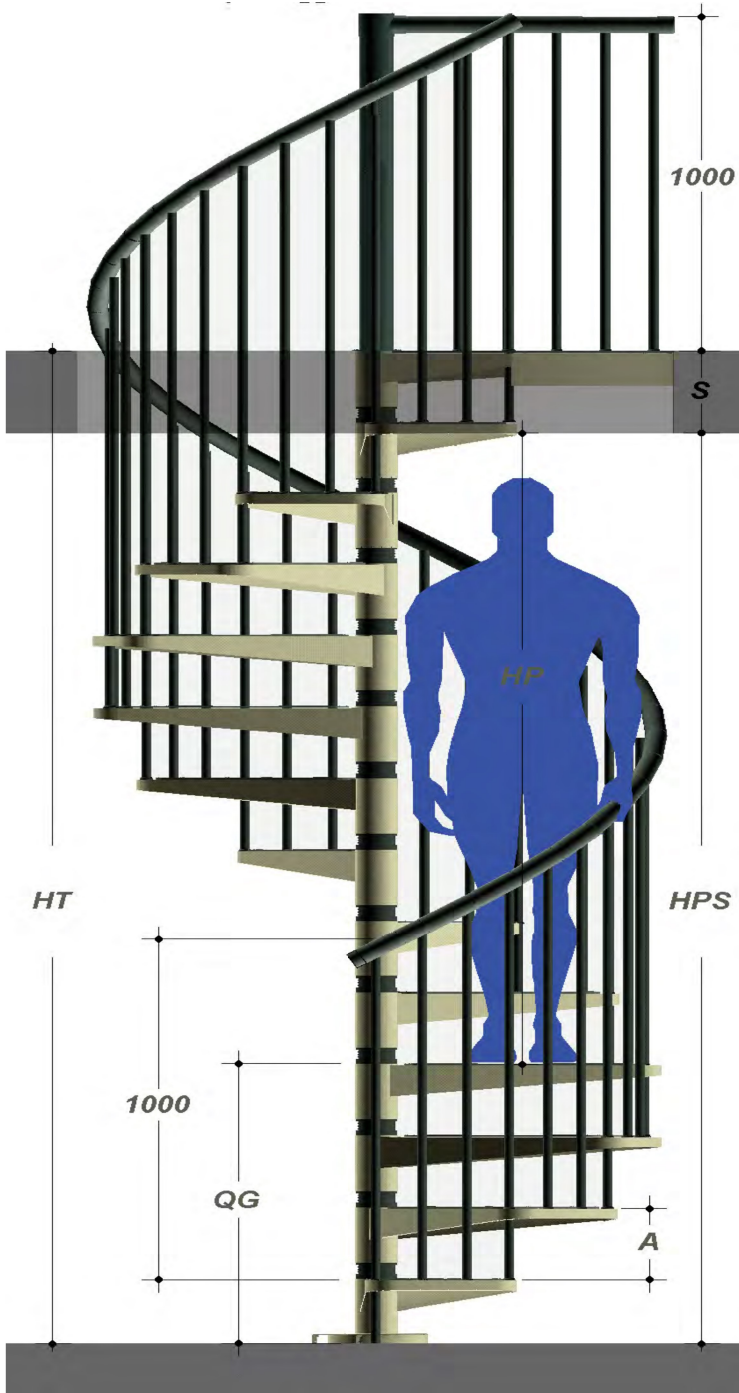

HT - Altezza totale da pavimento a pavimento (HPS+S)
 HPS - Altezza da pavimento inferiore a soffitto (HT-S)
 S - Spessore solaio (HT-HPS)
 A - Altezza alzata (HT/Nr. alzate)

HT - Hauteur totale sol fini à sol fini (HPS+S)
 HPS - Hauteur sous plafond (HT-S)
 S - Epaisseur de la dalle (HT-HPS)
 A - Hauteur de la marche
 (Hauteur totale:n.hauteurs de marches)

HT - Altura total de suelo a suelo (HPS+S)
 HPS - Altura de suelo inferior a techo (HT-S)
 S - Espesor de la losa o piso (HT-HPS)
 A - Altura contrahuella (HT / Nr. contrahuellas)

HT - Floor-to-floor height (HPS+S)
 HPS - Floor-to-ceiling height (HT-S)
 S - Floor thickness (HT-HPS)
 A - Riser height (HT : riser number)

HT - Höhe Oberkante Fertigfußboden / Oberkante Fertigfußboden (HPS+S) "93Stockwerkshöhe"93
 HPS - Höhe Oberkante Fertigfußboden / Decke (HT-S)
 S - Deckenstärke (HT-HPS)
 A - Steigung (HT : Anzahl der Steigungen)

HT - Altura total de pavimento a pavimento (HPS+S)
 HPS - Altura do pavimento inferior ao teto (HT - S)
 S - Espessura soalho (HT - HPS)
 A - Altura do degrau (HT/Nr. Alturas do degrau)

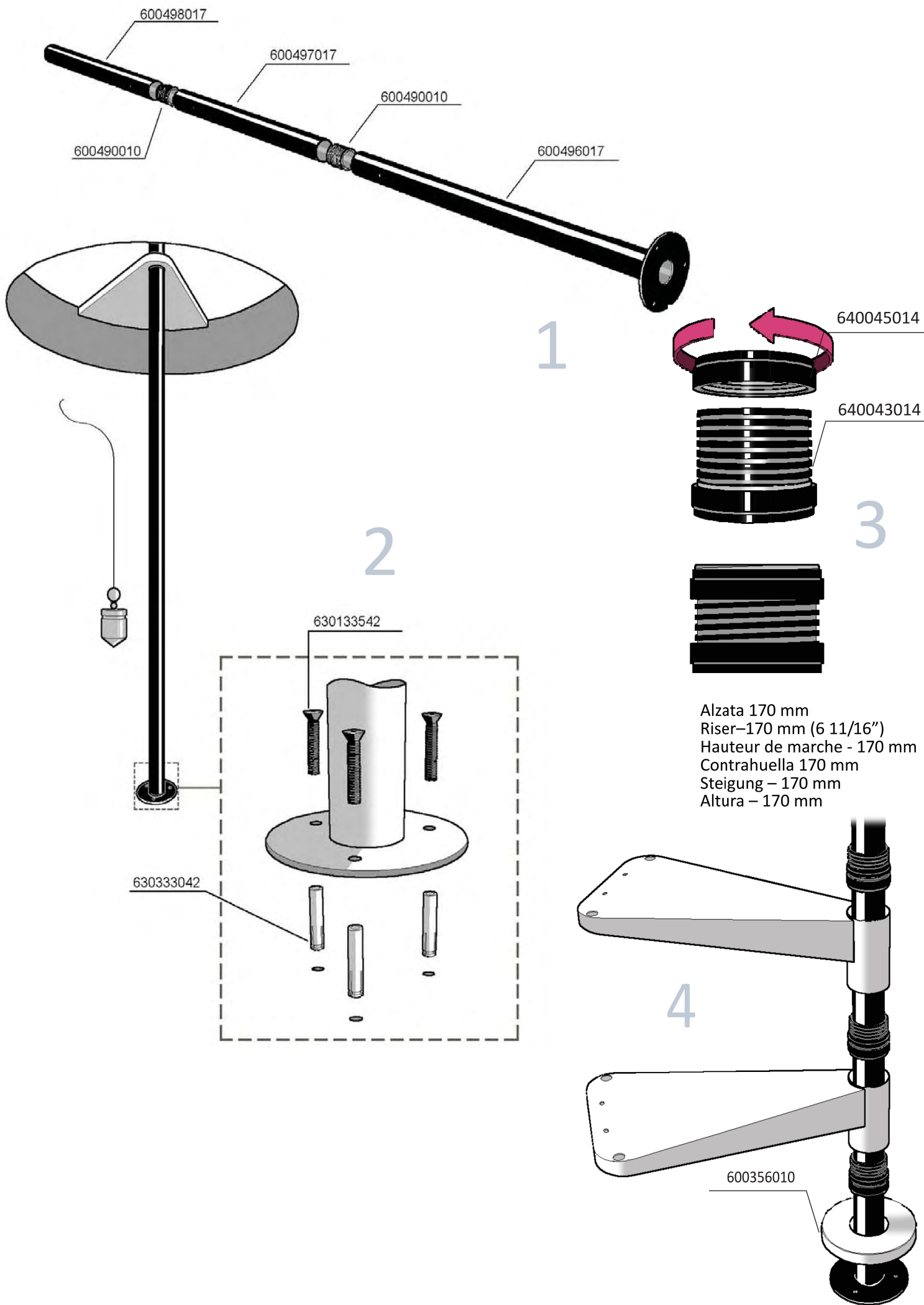

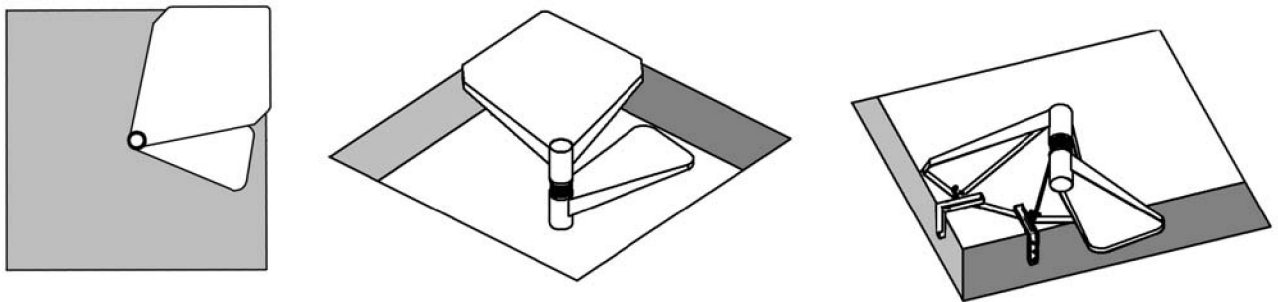
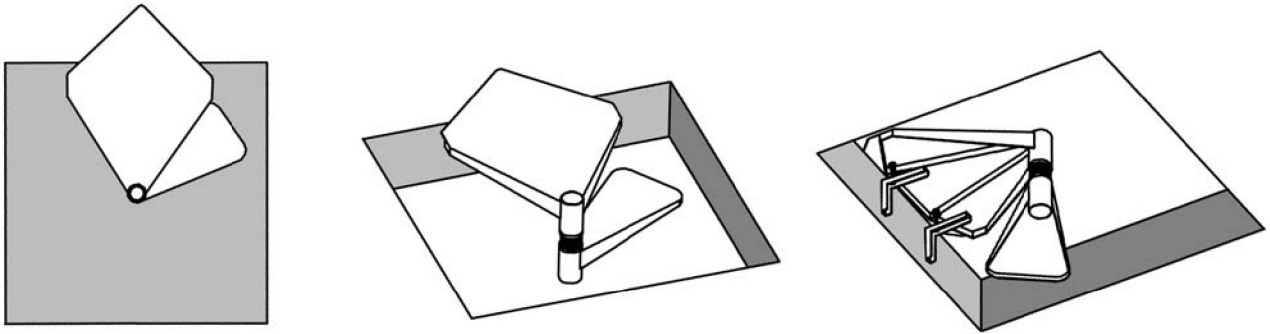
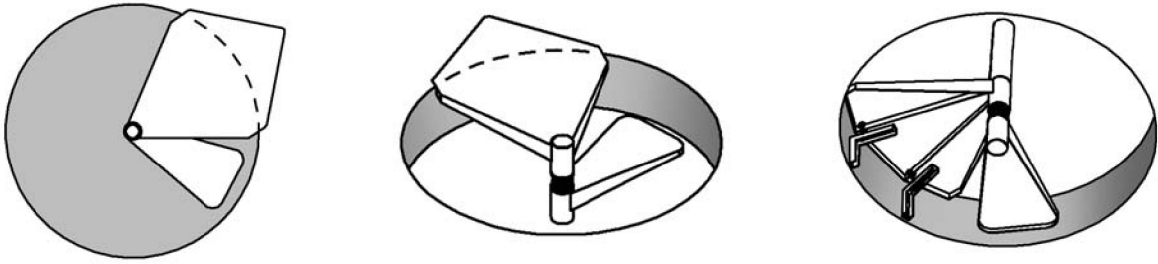

5

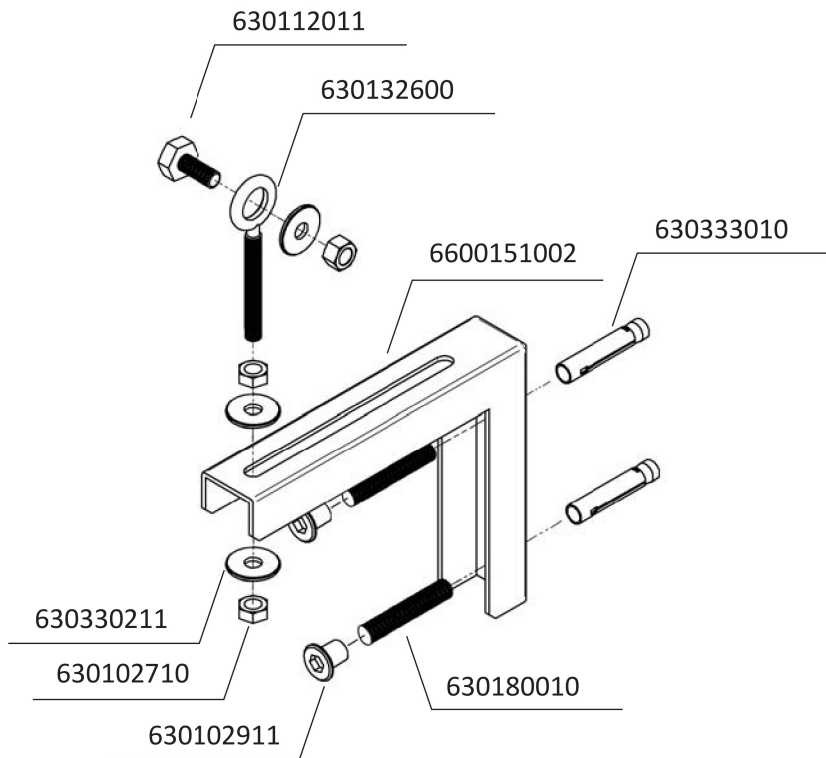

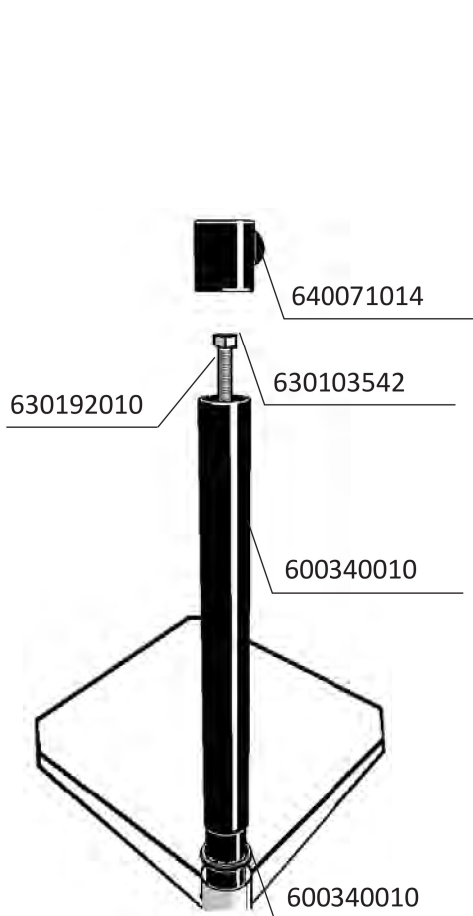

6

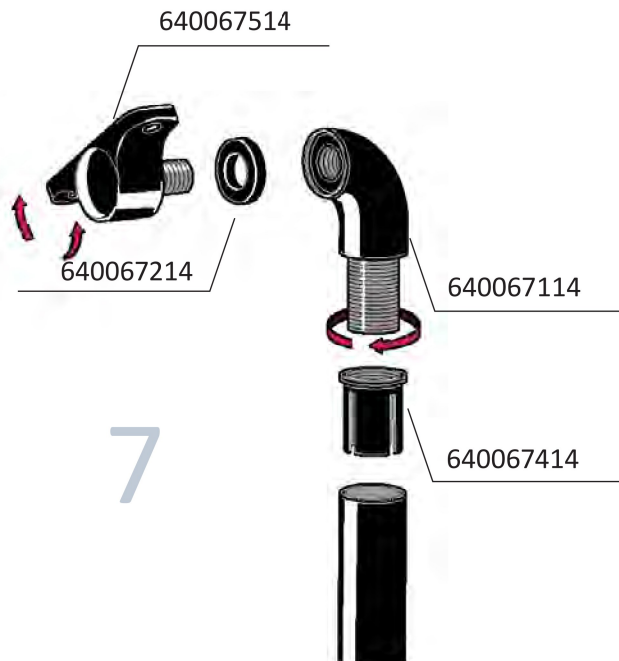

7

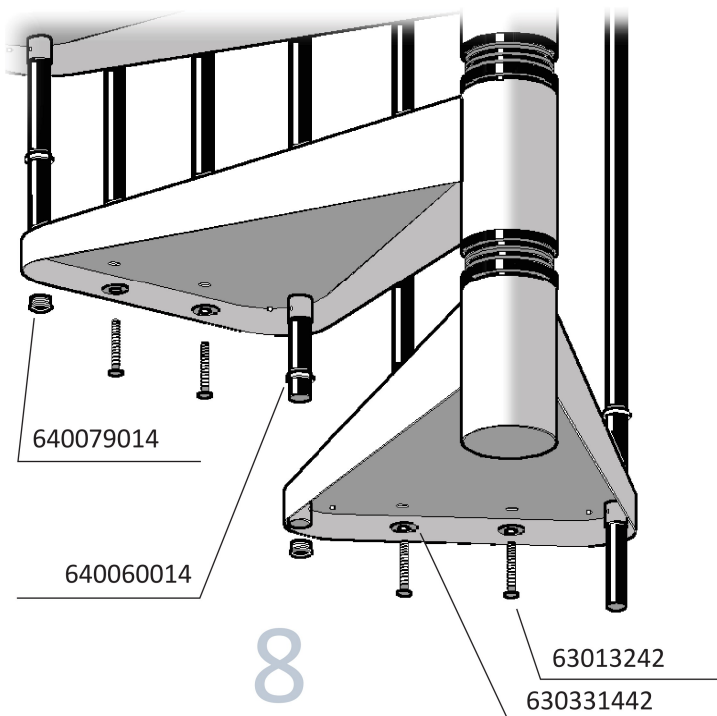

8

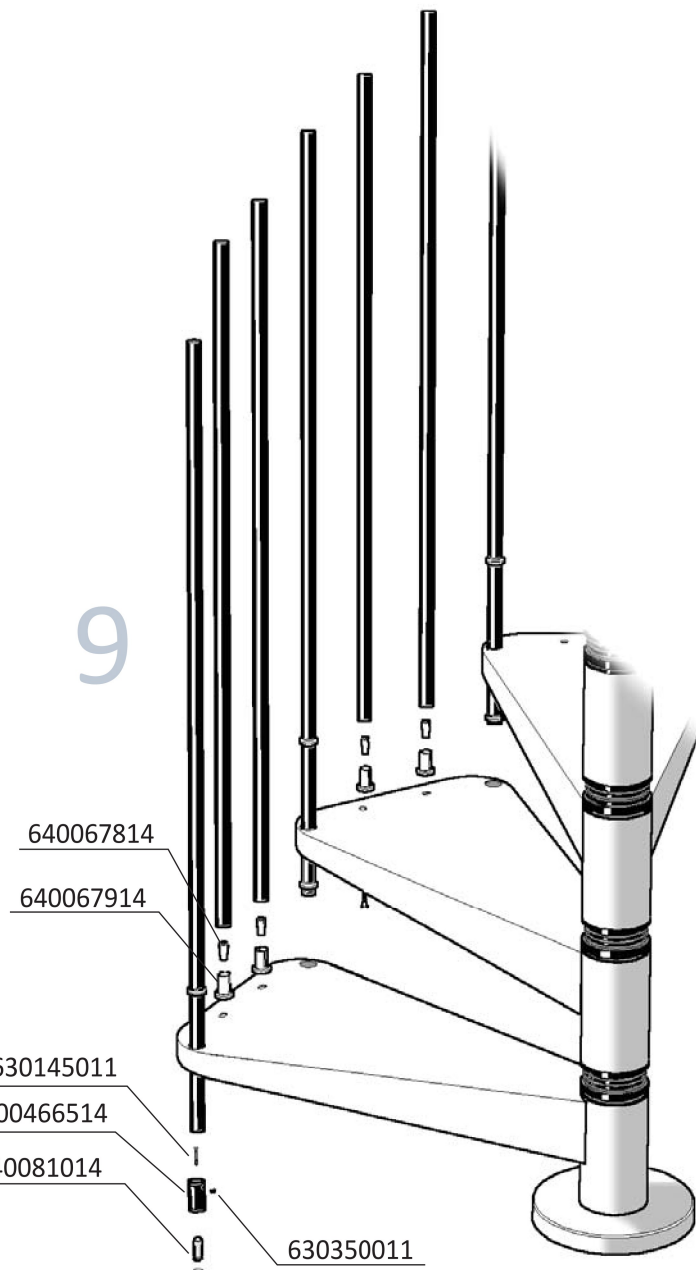

9

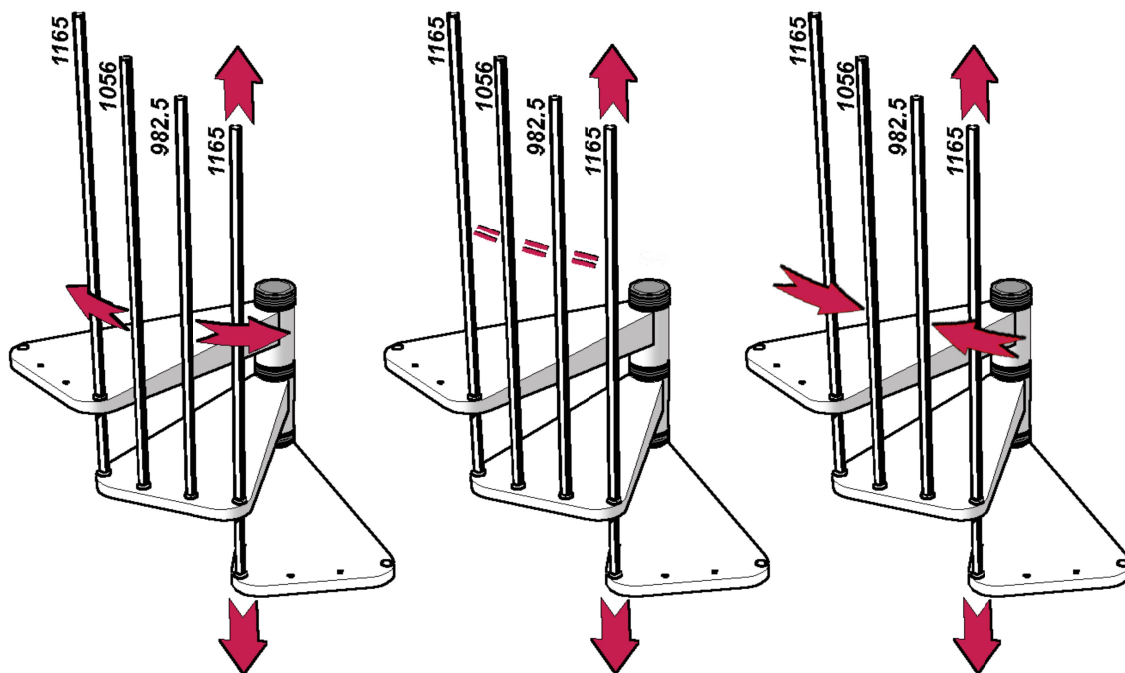

Ø scala / stair/ escalier / escalera/ treppe/ escada
120 – 140 mm; (47 1/4" - 55 1/8");

10

Ø scala / stair/ escalier / escalera/ treppe/escada
160 mm (63")

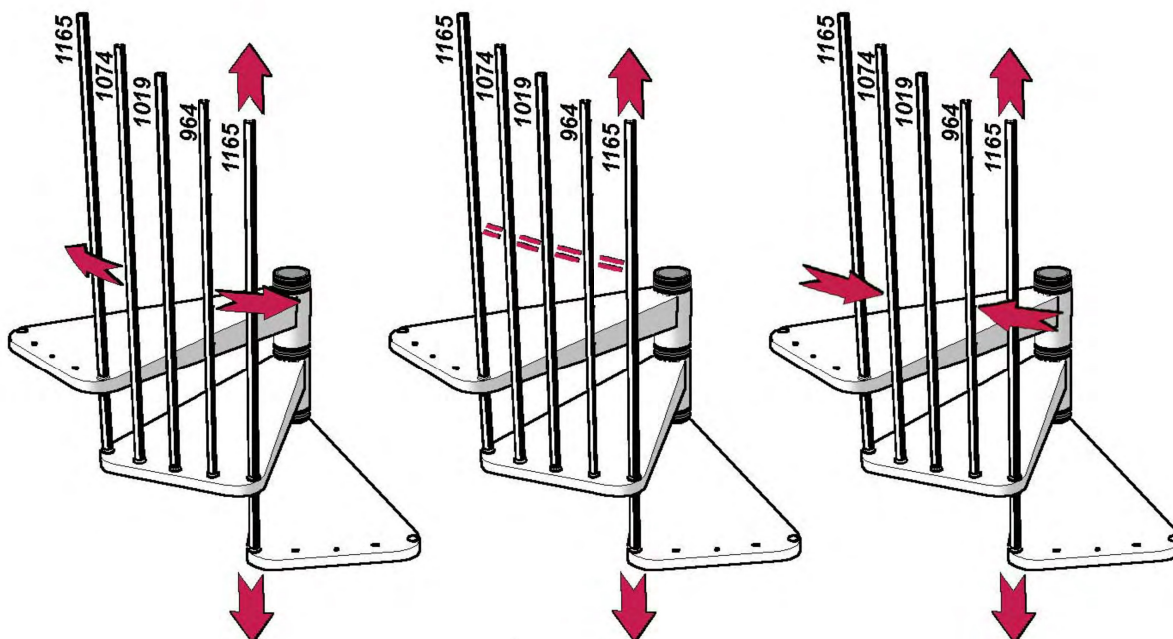



11

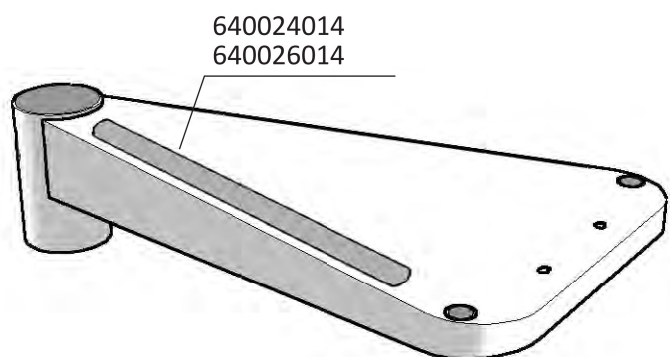





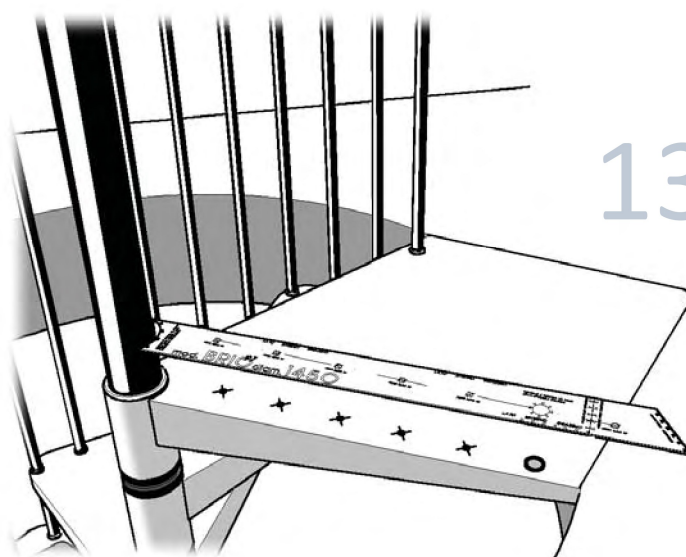



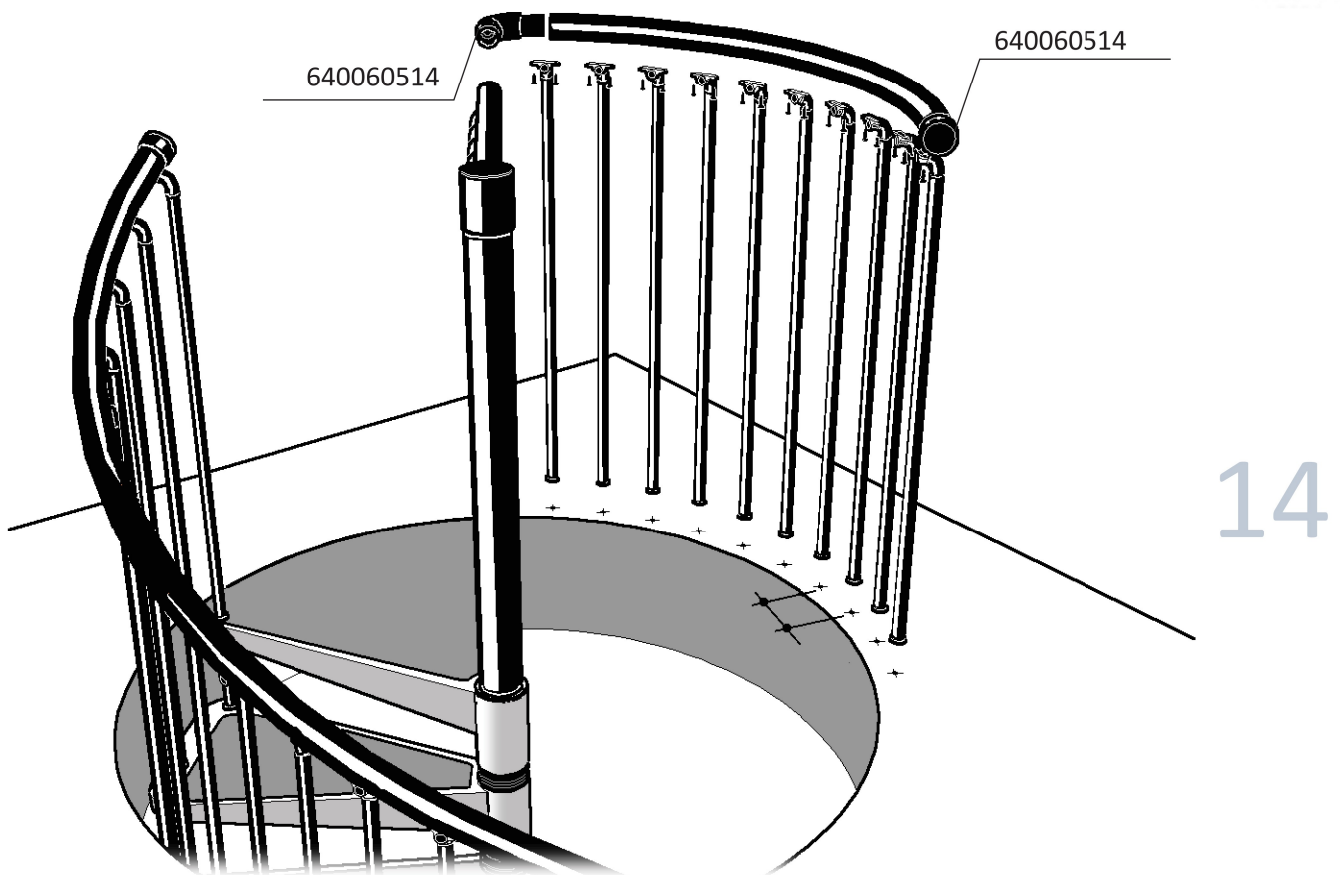
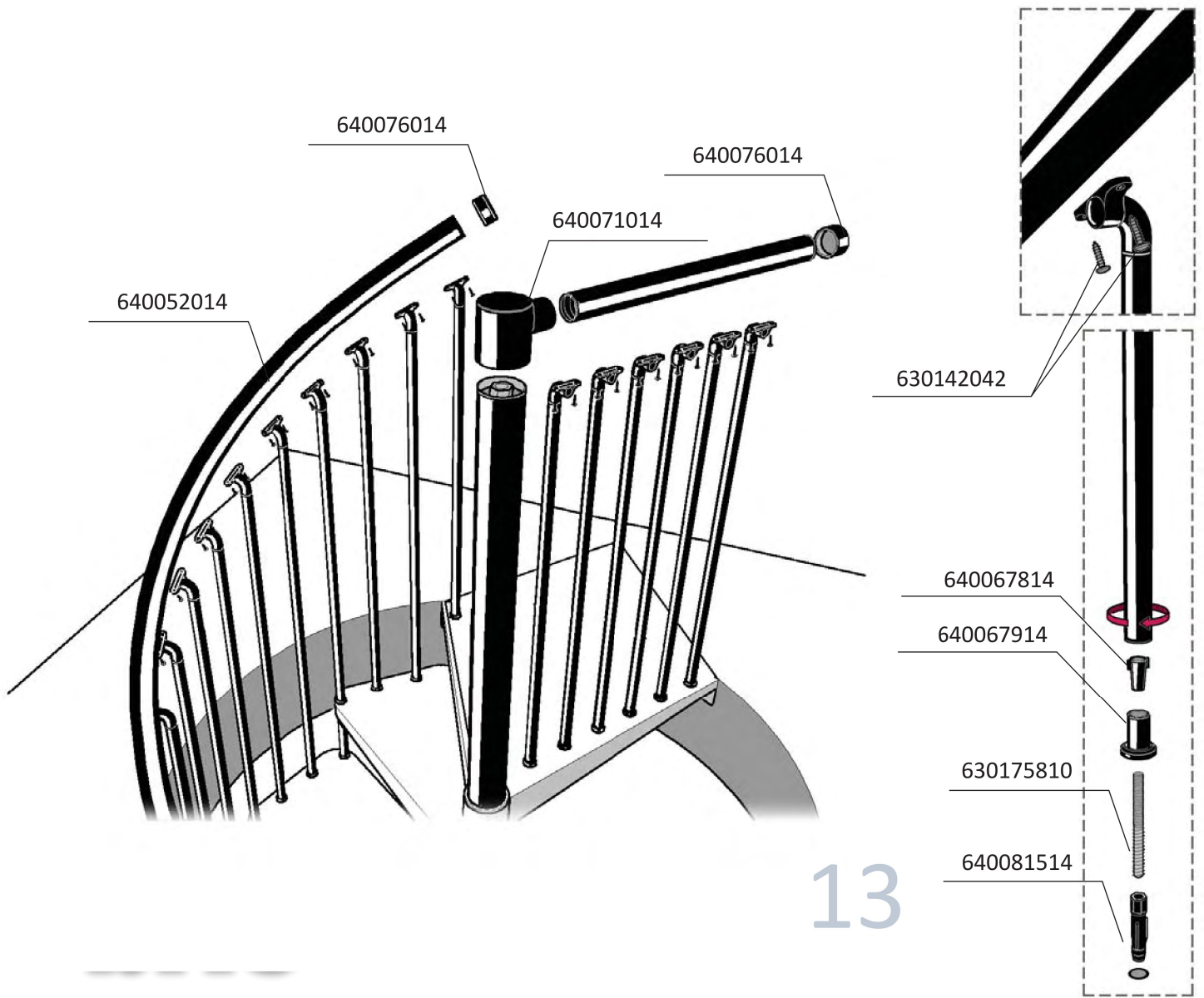

640024014
640026014

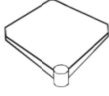
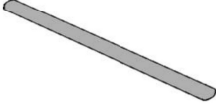
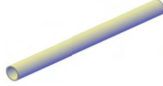
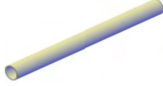
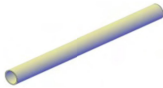
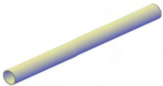
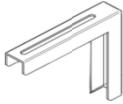















12











13

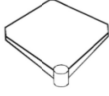
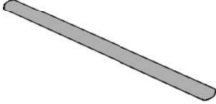
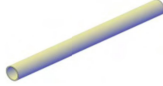
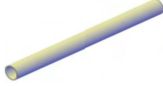
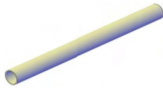
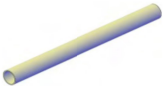
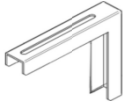































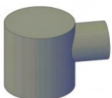

Ø 1200	KIT 12+1	COD.	IMAGE
	12	600042002	
	1	600100202	
	13	640024014	
	5	600230514	
	12	600231714	
	12	600232514	
	14	600233014	
	2	600151002	
	1	600343002	
	1	600356002	
	2	600490000	
	1	600496002	
	1	600497002	
	1	600498002	
	1	600340002	
	1	600467514	









Ø 1200	KIT 12+1	COD.	IMAGE
	2	600466514	
	1	630103510	
	6	630102710	
	88	630142011	
	2	630145011	
	4	630180010	
	2	630132600	
	3	630133511	
	30	630132011	
	2	630112011	
	1	630192000	
	42	630350011	
	7	630333010	
	4	630102911	
	30	630331411	
	6	630330211	

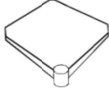
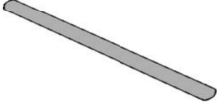
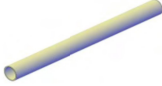
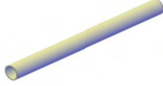
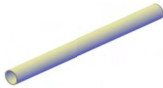
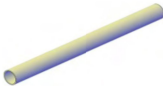
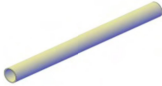
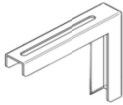















Ø 1200	KIT 12+1	COD.	IMAGE
	1	9964520	
	44	640067114	
	44	640067214	
	44	640067414	
	44	640067514	
	1	640071014	
	3	640076014	
	12	640079014	
	1	650800000	
	13	640043014	
	13	640045014	
	30	640067814	
	30	640067914	
	2	640081014	
	27	640060014	















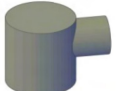

Ø 1400	KIT 12+1	COD.	IMAGE
	12	600044002	
	1	600100402	
	13	640026014	
	5	600230514	
	12	600231714	
	12	600232514	
	14	600233014	
	2	600151002	
	1	600343002	
	1	600356002	
	2	600490000	
	1	600496002	
	1	600497002	
	1	600498002	
	1	600340002	
	1	600467514	

Ø 1400	KIT 12+1	COD.	IMAGE
	2	600466514	
	1	630103510	
	6	630102710	
	88	630142011	
	2	630145011	
	4	630180010	
	2	630132600	
	3	630133511	
	30	630132011	
	2	630112011	
	1	630192000	
	42	630350011	
	7	630333010	
	4	630102911	
	30	630331411	
	6	630330211	

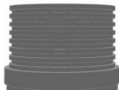
Ø 1400	KIT 12+1	COD.	IMAGE
	-	9964520	
	1	9964525	
	44	640067114	
	44	640067214	
	44	640067414	
	44	640067514	
	1	640071014	
	3	640076014	
	11	640079014	
	1	650800000	
	13	640043014	
	13	640045014	
	30	640067814	
	30	640067914	
	2	640081014	
	27	640060014	

Ø 1600	Q. KIT 12+1	COD.	IMAGE
	12	600044002	
	1	600100402	
	13	640026014	
	6	600230514	
	12	600231714	
	12	600232514	
	12	600232714	
	14	600233014	
	2	600151002	
	1	600343002	
	1	600356002	
	2	600490000	
	1	600496002	
	1	600497002	
	1	600498002	
	1	600340002	

Ø 1600	Q. KIT 12+1	COD.	IMAGE
	2	600467514	
	3	600466514	
	1	630103510	
	6	630102710	
	114	630142011	
	3	630145011	
	4	630180010	
	2	630132600	
	3	630133511	
	43	630132011	
	2	630112011	
	1	630192000	
	43	630350011	
	7	630333010	
	4	630102911	
	43	630331411	

Ø 1600	Q. KIT 12+1	COD.	IMAGE
	6	630330211	
	1	9964525	
	57	640067114	
	57	640067214	
	57	640067414	
	57	640067514	
	1	640071014	
	3	640076014	
	12	640079014	
	1	650800000	
	13	640043014	
	13	640045014	
	43	640067814	
	43	640067914	
	3	640081014	
	26	640060014	



Stair Studio S.r.l.

VIA GIACOMO FILIPPI, 7
47122 FORLI' (FC) ITALY
TEL. + 39.0543.791111
FAX + 39.0543.722544
www.rintal.com info@rintal.it