

650532000

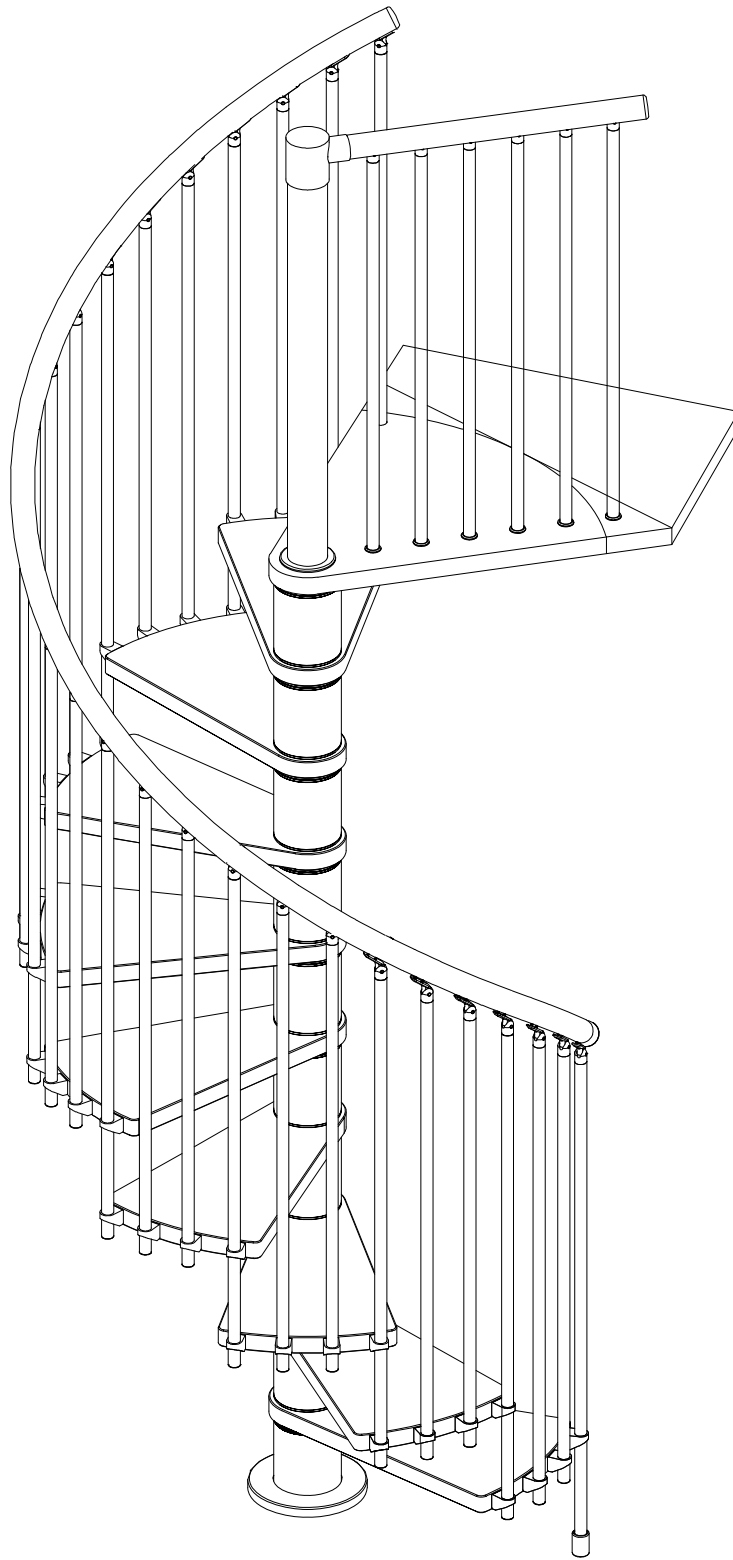

ISTRUZIONI DI POSA
ASSEMBLY INSTRUCTIONS

ASSEMBLAGGIO PALO INTERNO / INTERNAL POLE ASSEMBLY

226<HT<321

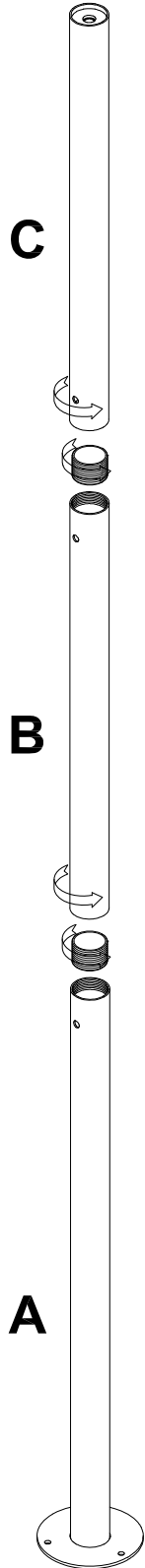

HT>321

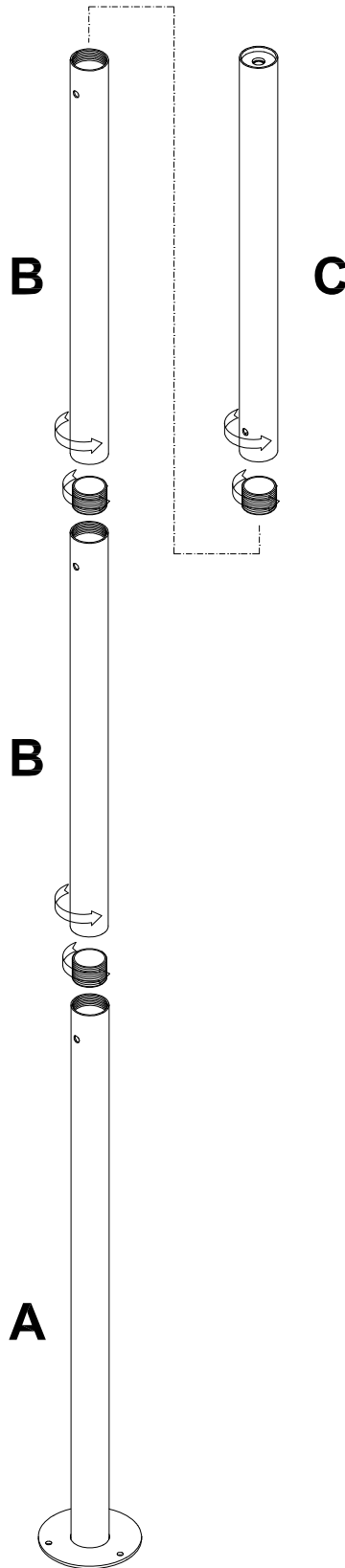

HT<226

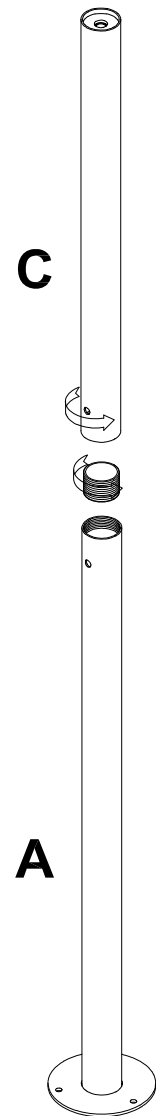

PREPARAZIONE GRADINO DI SBARCO / LANDING TREAD PREPARATION

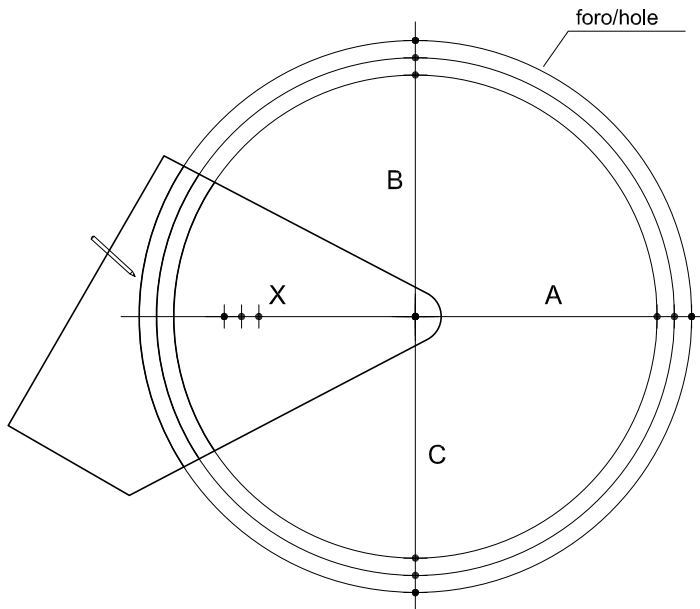

Ø105

X, A, B, C: min 55 cm
X: max 62,5 cm

Ø120

X, A, B, C: min 62,5 cm
X: max 72,5 cm

Ø140

X, A, B, C: min 72,5 cm
X: max 82,5 cm

Ø160

X, A, B, C: min 82,5 cm
X: max 92,5 cm

Ø180

X, A, B, C: min 92,5 cm
X: max 100 cm

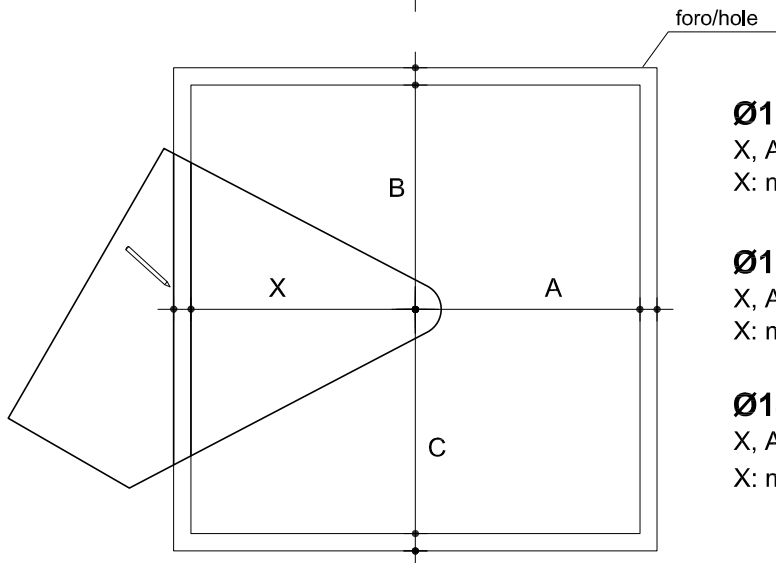

Ø105

X, A, B, C: min 55 cm
X: max 56,5 cm

Ø120

X, A, B, C: min 62,5 cm
X: max 65 cm

Ø140

X, A, B, C: min 72,5 cm
X: max 75 cm

Ø160

X, A, B, C: min 82,5 cm
X: max 85 cm

Ø180

X, A, B, C: min 92,5 cm
X: max 95 cm

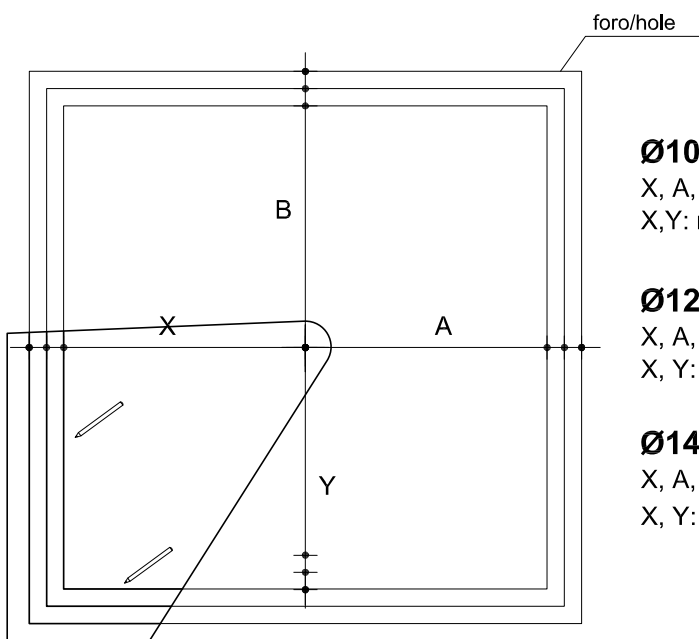

Ø105

X, A, B, C: min 55 cm
X, Y: max 62,5 cm

Ø120

X, A, B, C: min 62,5 cm
X, Y: max 72,5 cm

Ø140

X, A, B, C: min 72,5 cm
X, Y: max 82,5 cm

Ø160

X, A, B, C: min 82,5 cm
X, Y: max 92,5 cm

Ø180

X, A, B, C: min 92,5 cm
X, Y: max 100 cm

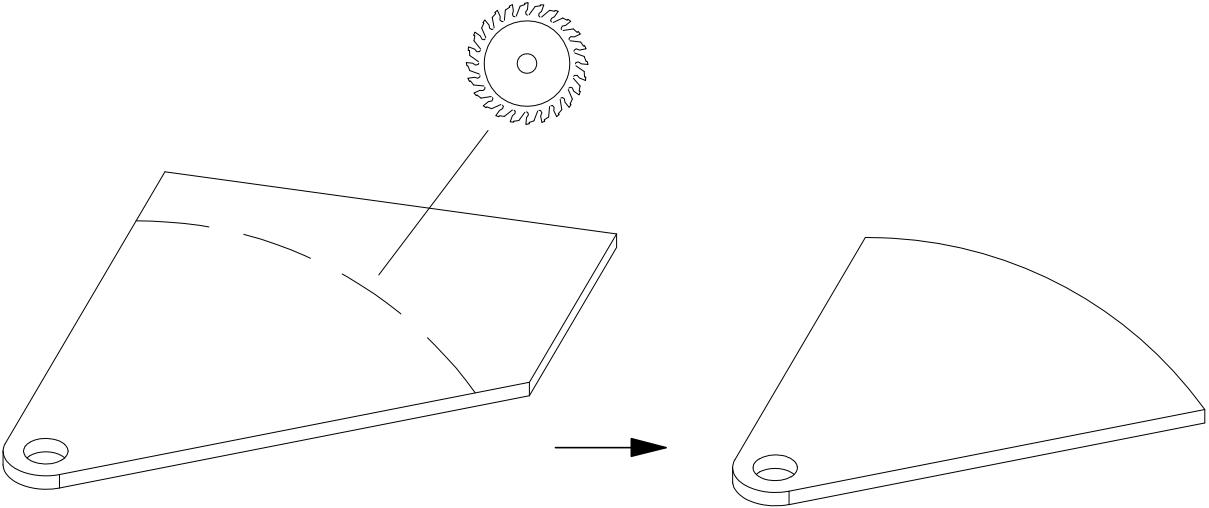
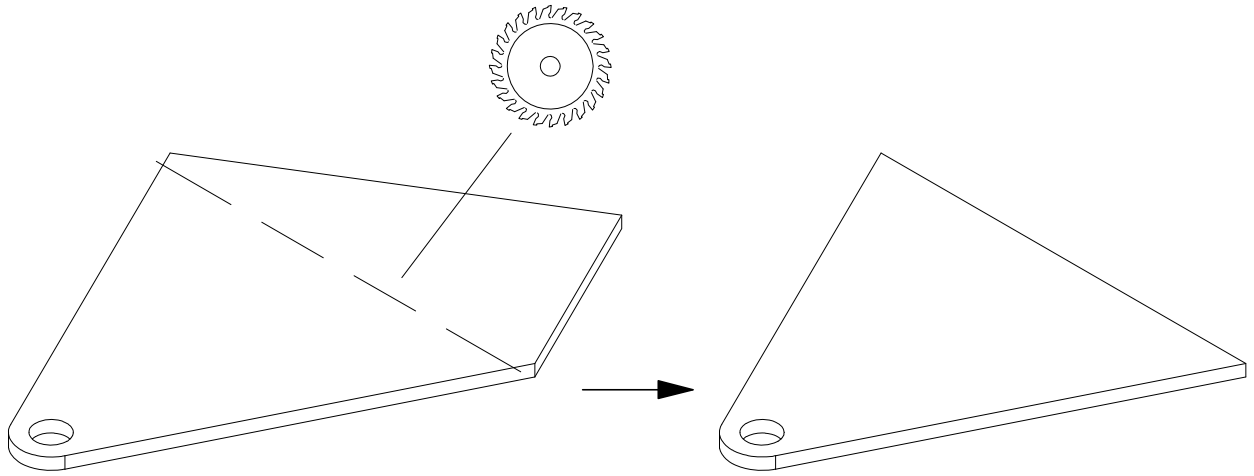
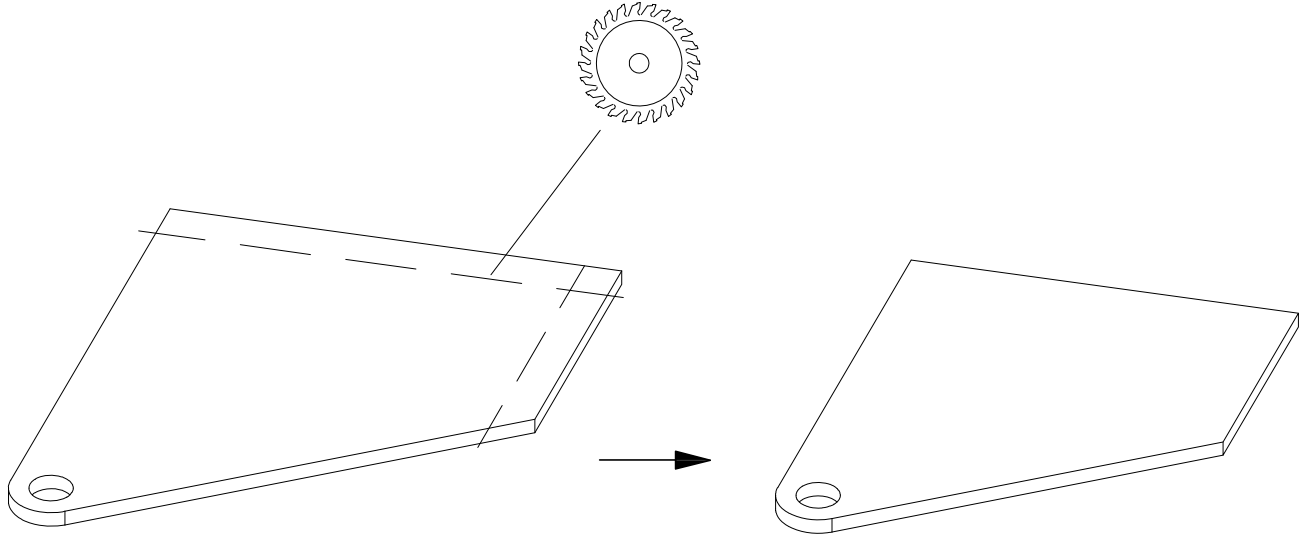



ESEMPIO: SBARCO TESTA DRITTA
EXAMPLE: TRIANGULAR LANDING

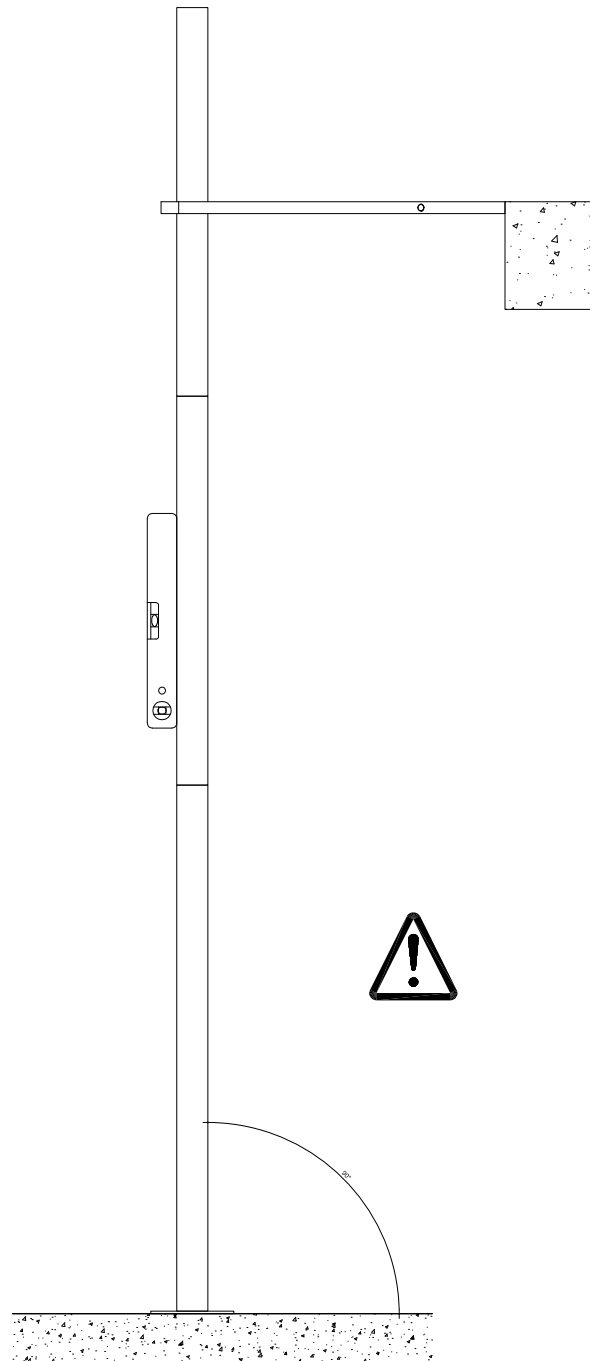
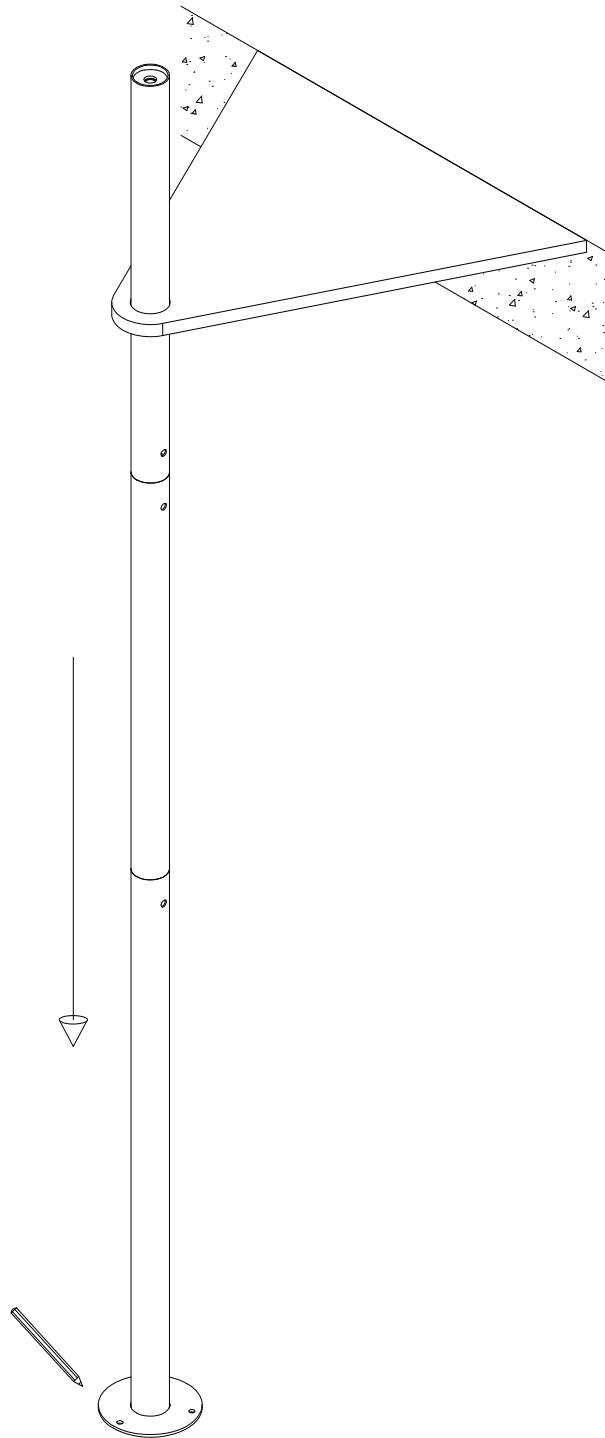
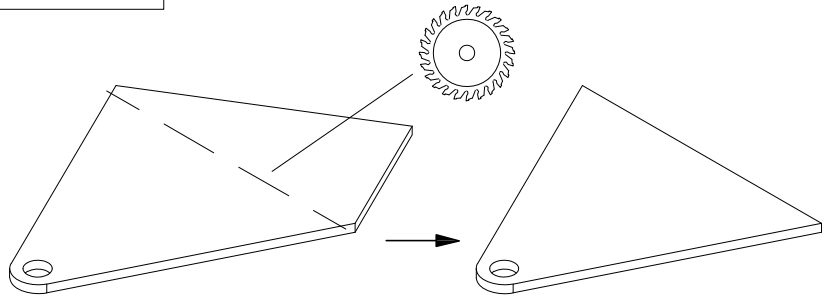

FISSAGGIO A TERRA / GROUND FIXING

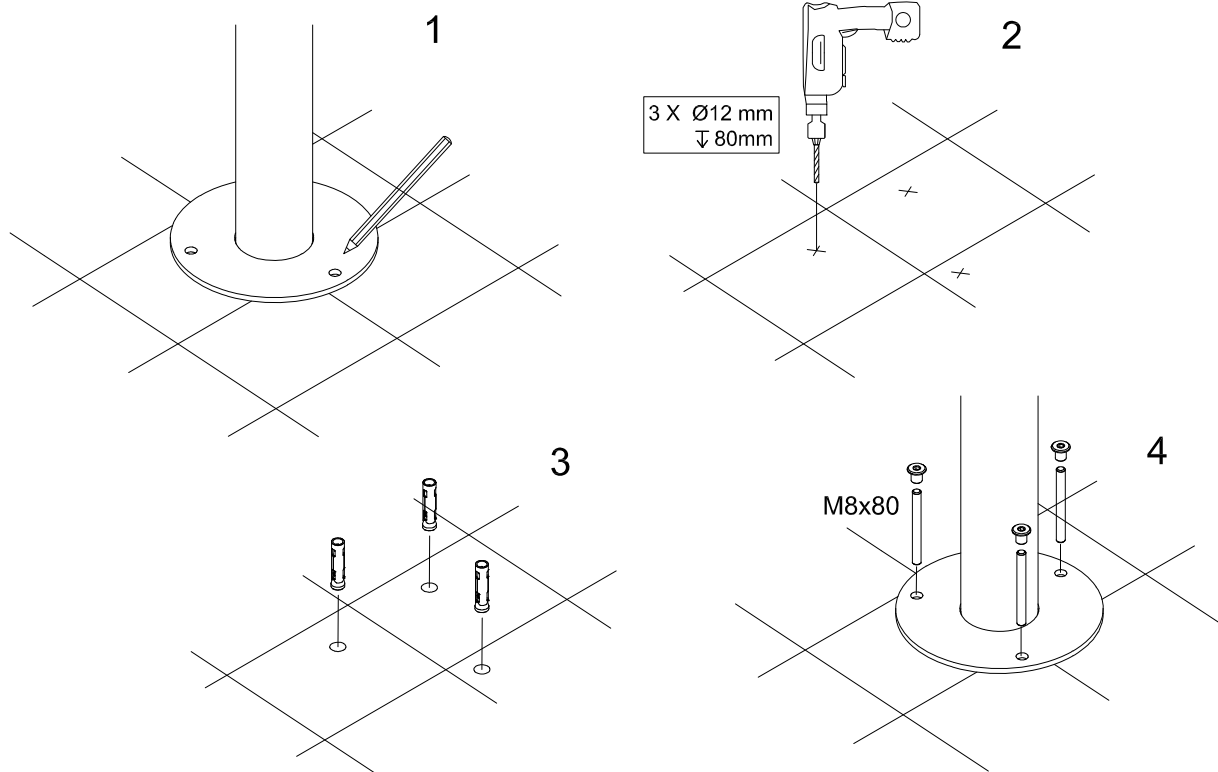

Viteria fornita idonea solo per cemento/muratura
Screws supplied suitable just for concrete

INSERIMENTO COPRIPIASTRA DI PARTENZA / INSERTING THE STARTING COVER

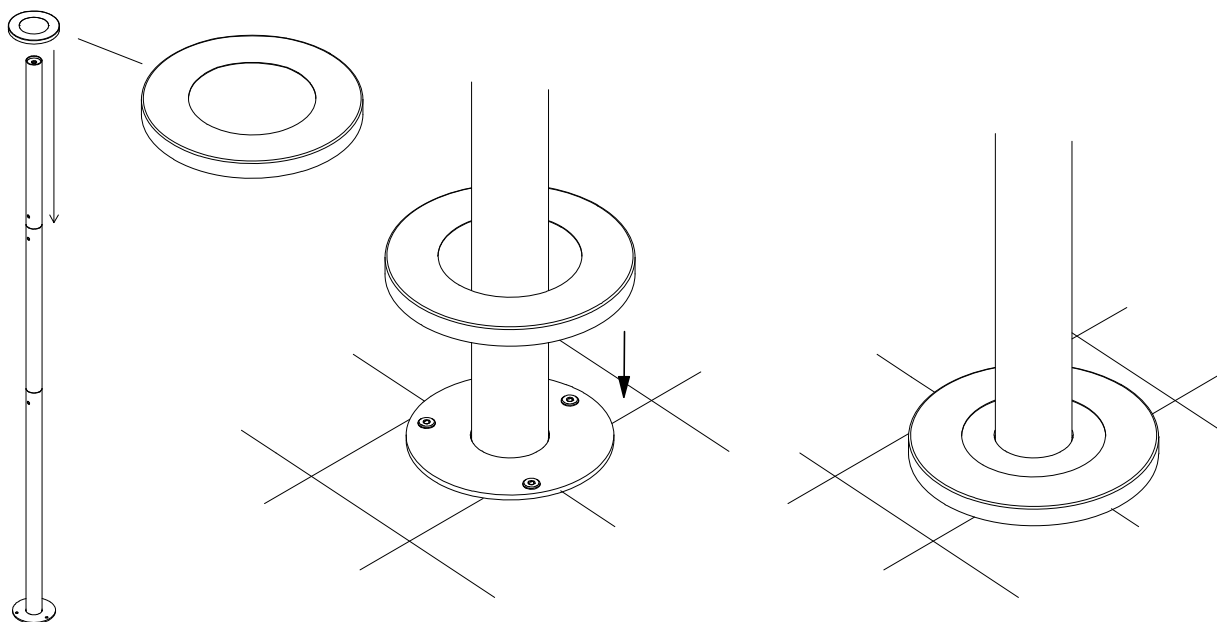

PUNZONATURA GRADINI PER RINGHIERA / STEP PUNCHIN FOR RAILING

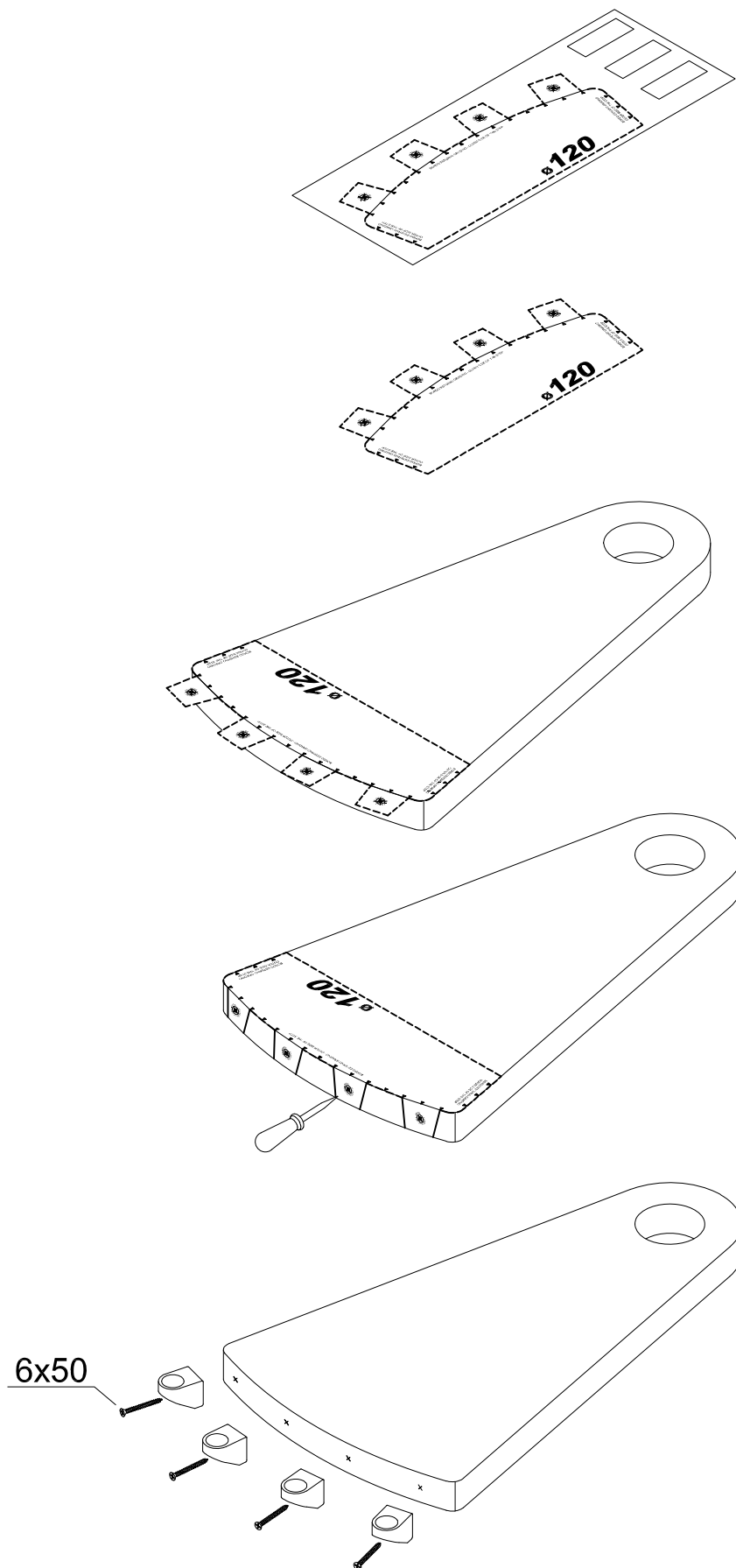

COMPOSIZIONE DELLE ALZATE / RISE COMPOSITION

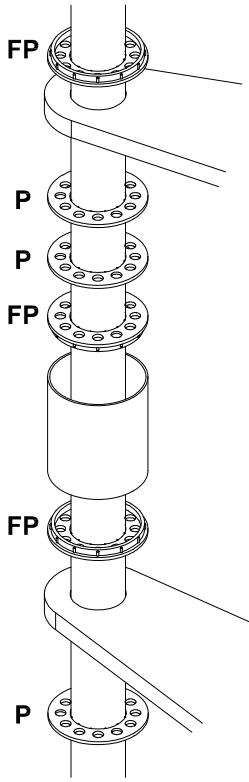

Alzata = 20,5



Alzata = 21

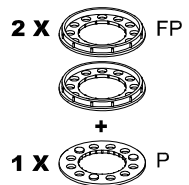

Alzata = 21.5

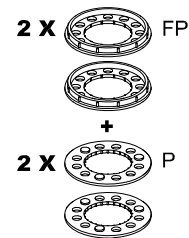

Alzata = 22

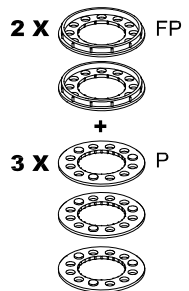

Alzata = 22.5

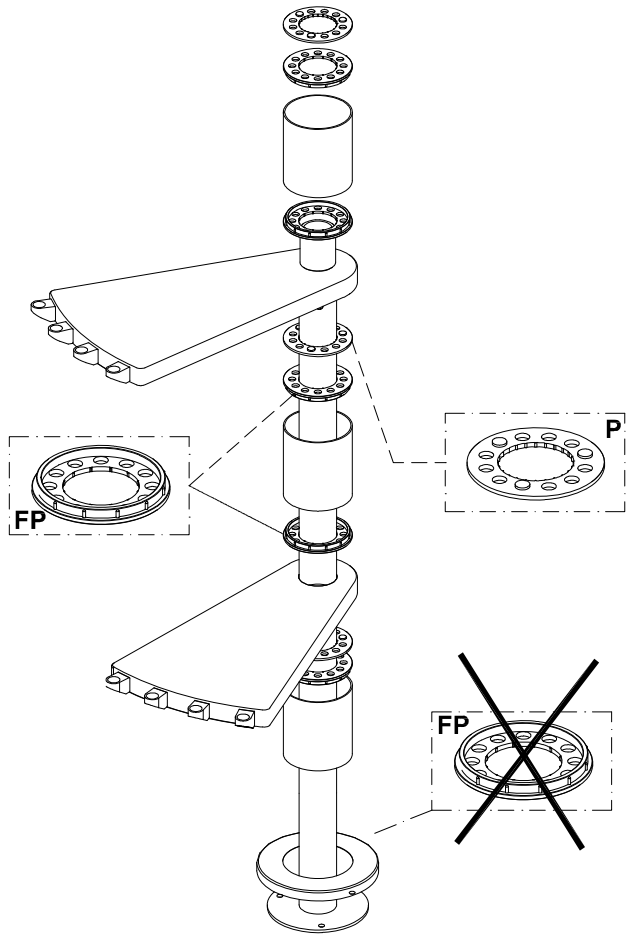
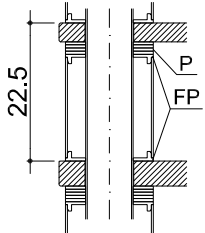
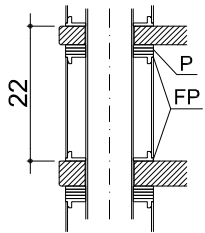
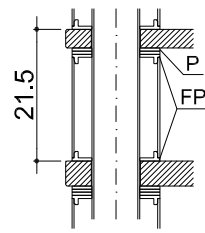
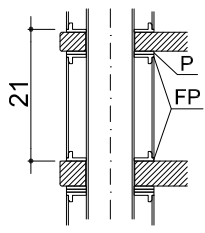
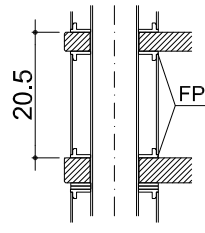
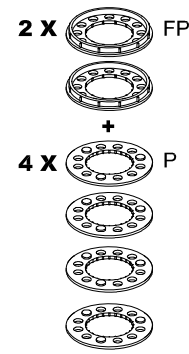

Alzata = 23

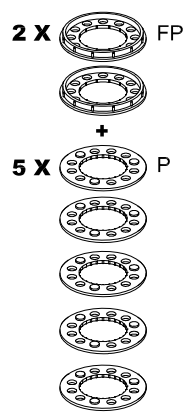

Alzata = 23.5

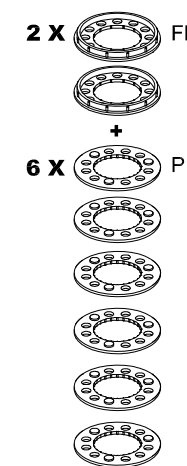

Alzata = 24

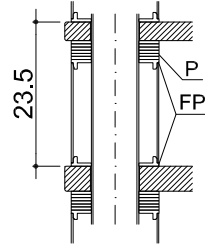
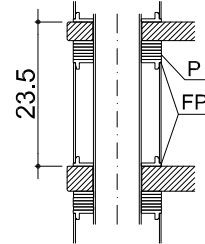
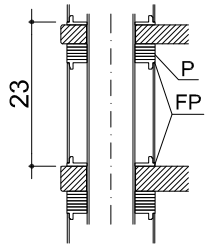
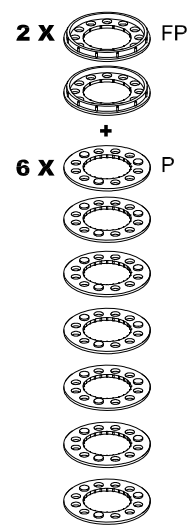

ASSEMBLAGGIO SCALA / STAIR ASSEMBLY

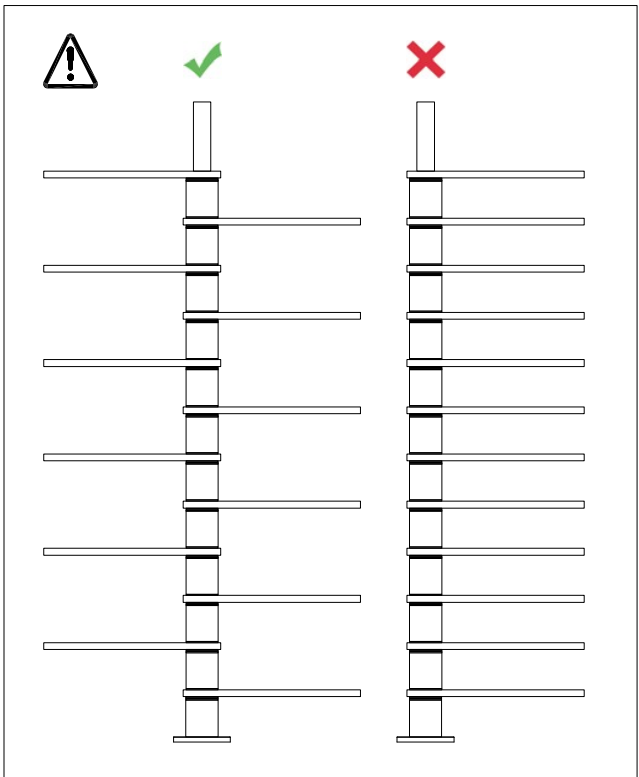
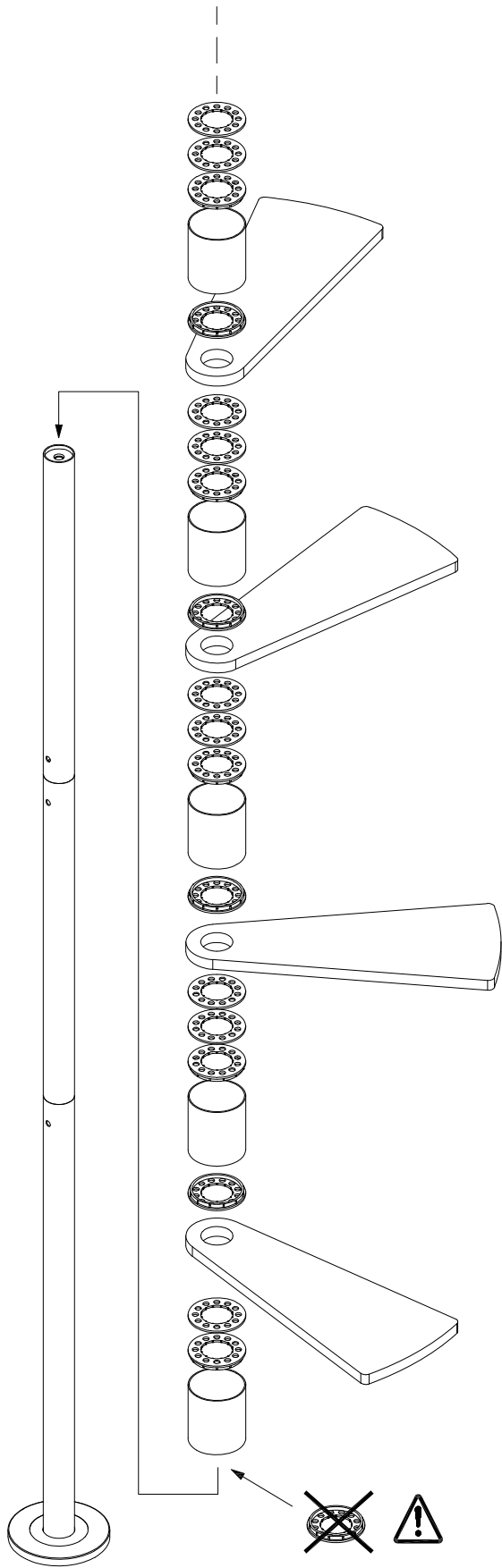

POSIZIONAMENTO GRADINO DI SBARCO / LANDING TREAD POSITIONING

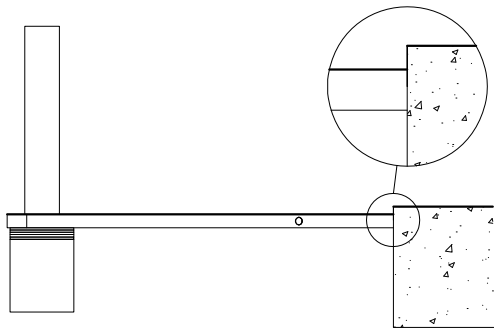
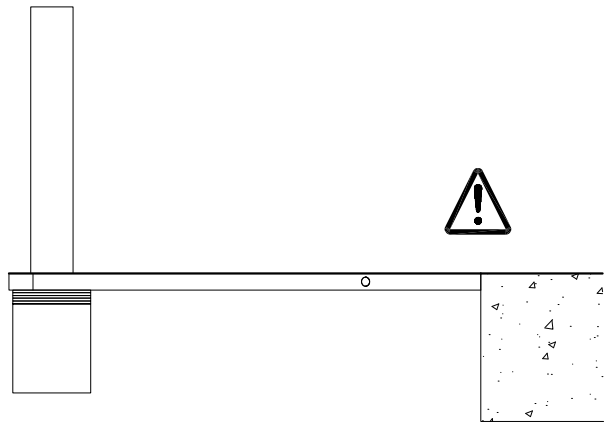
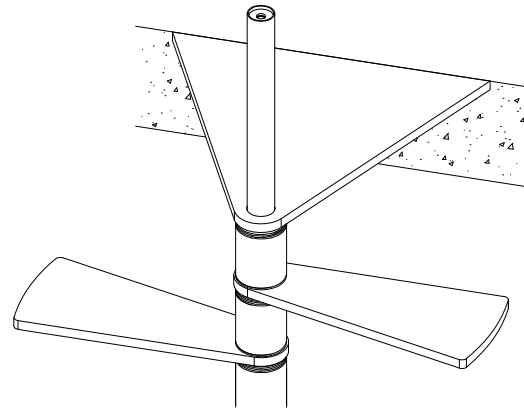
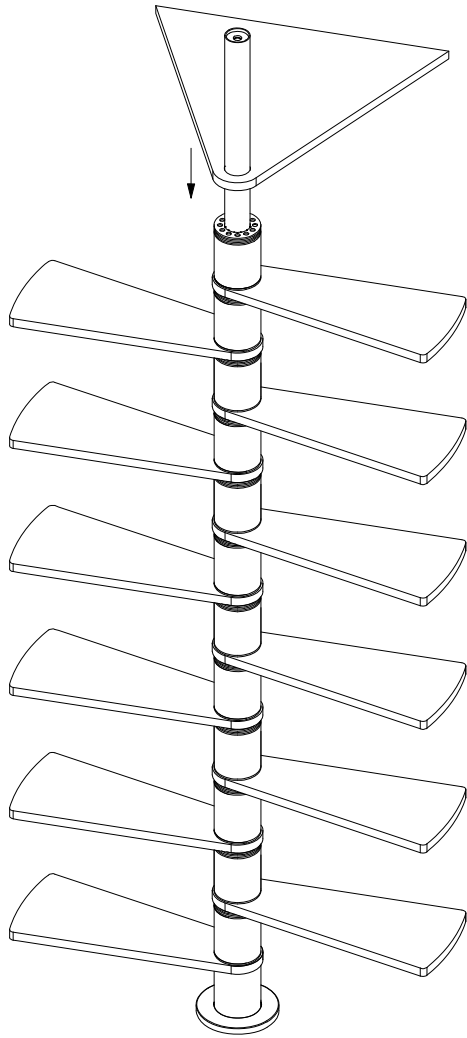

+

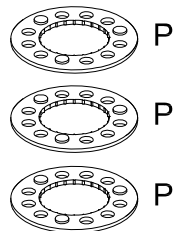

1 P = 0,5 cm

-

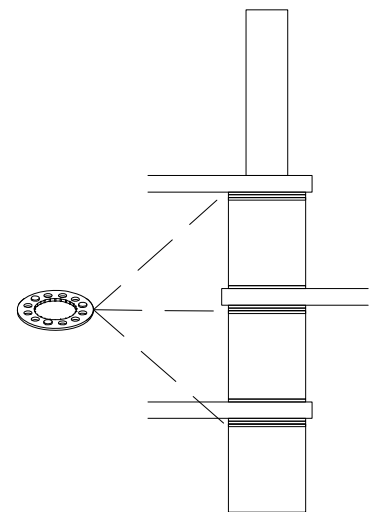
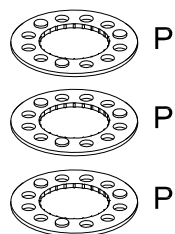

POSIZIONAMENTO STAFFE DI SBARCO / LANDING BRACKETS POSITIONING

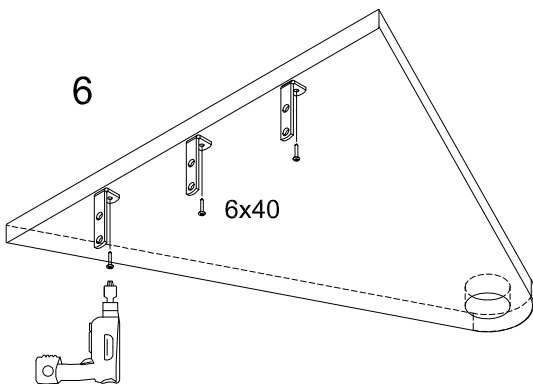
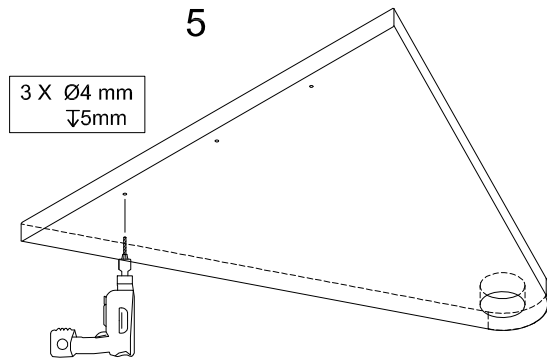
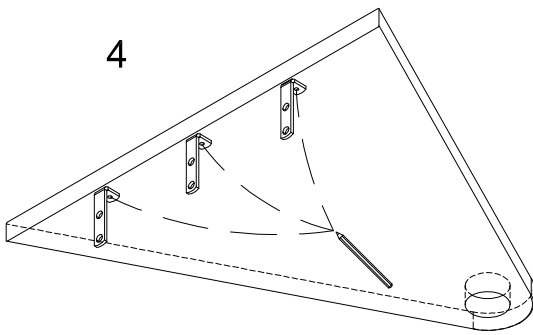
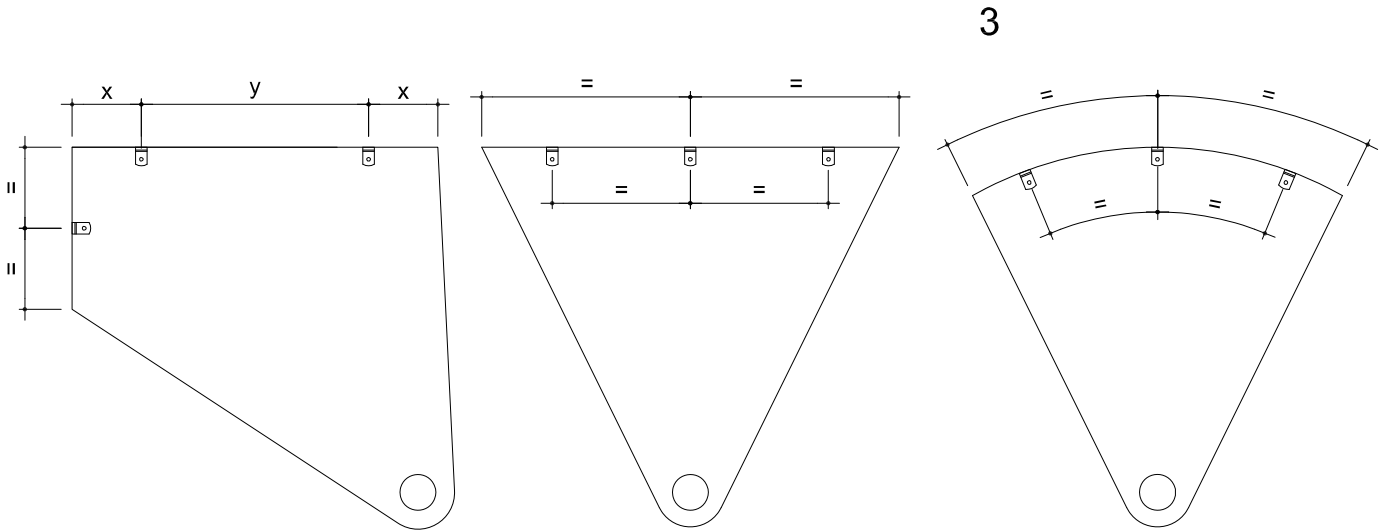
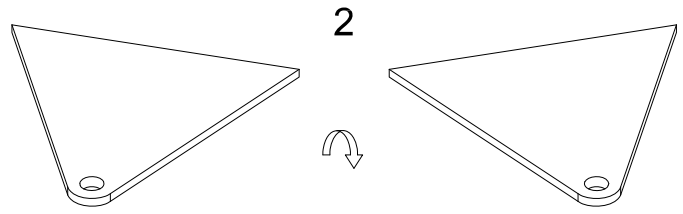
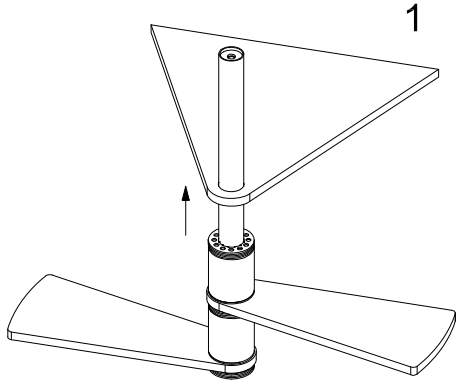

FISSAGGIO SCALA AL SOLAIO / HOW TO FIX THE STAIR TO THE SLAB

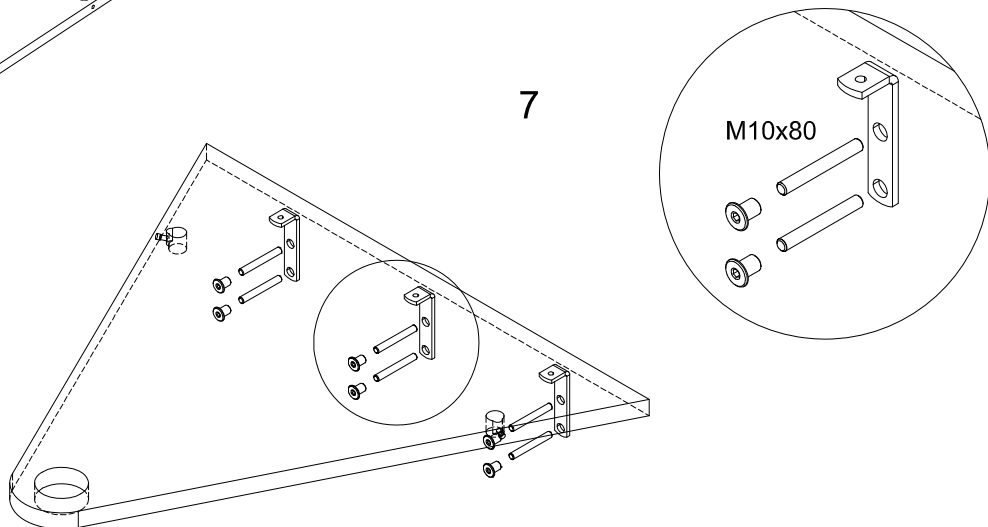
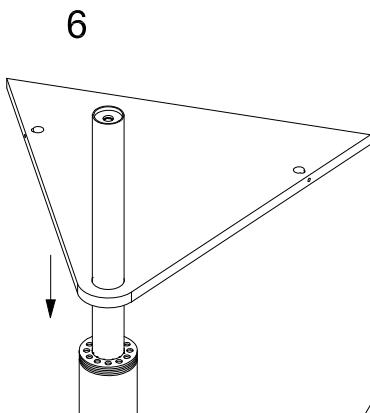
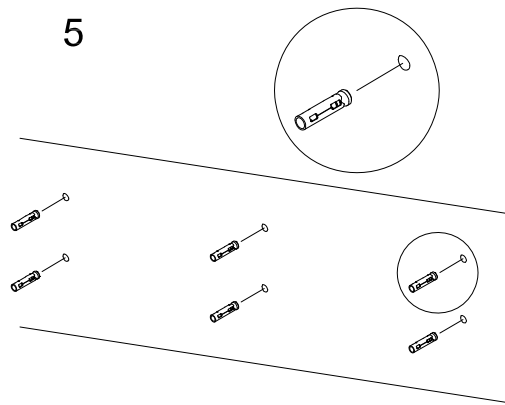
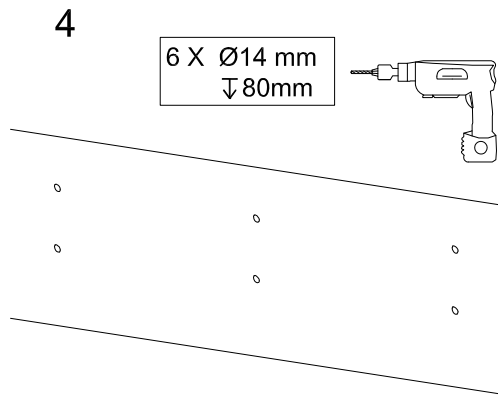
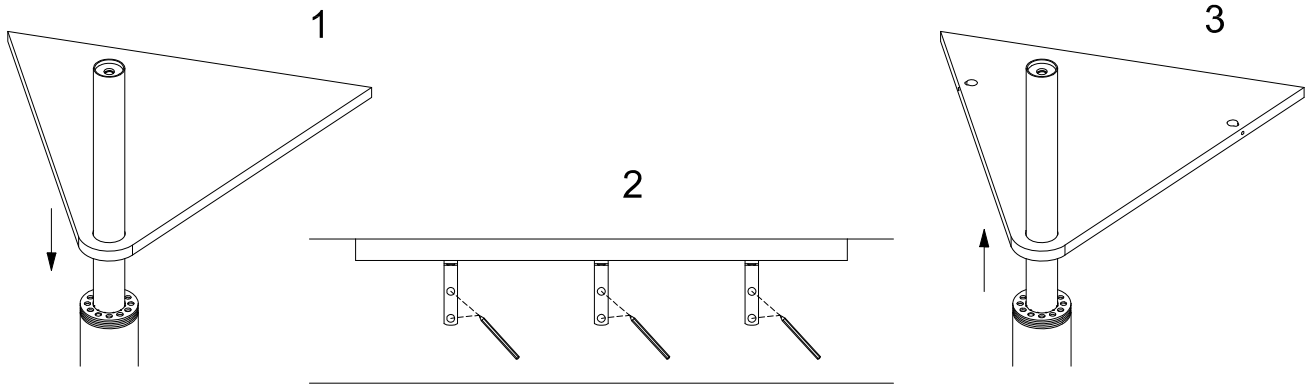

SERRAGGIO SCALA / STAIR TIGHTENING

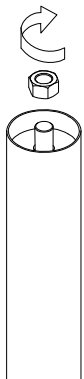
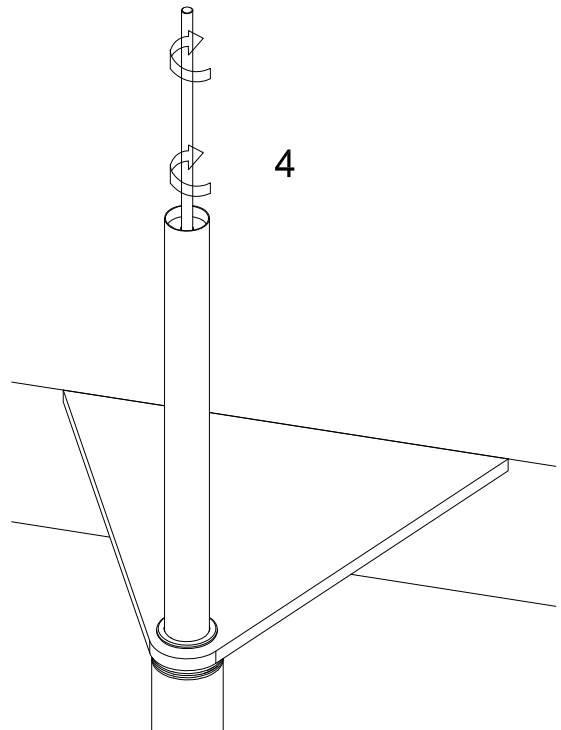
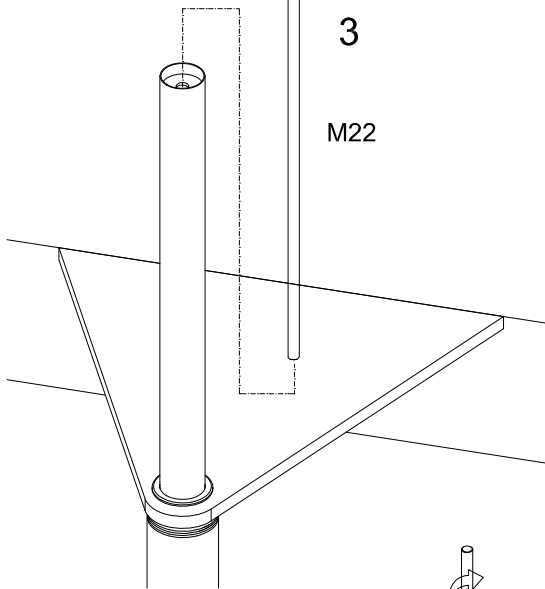
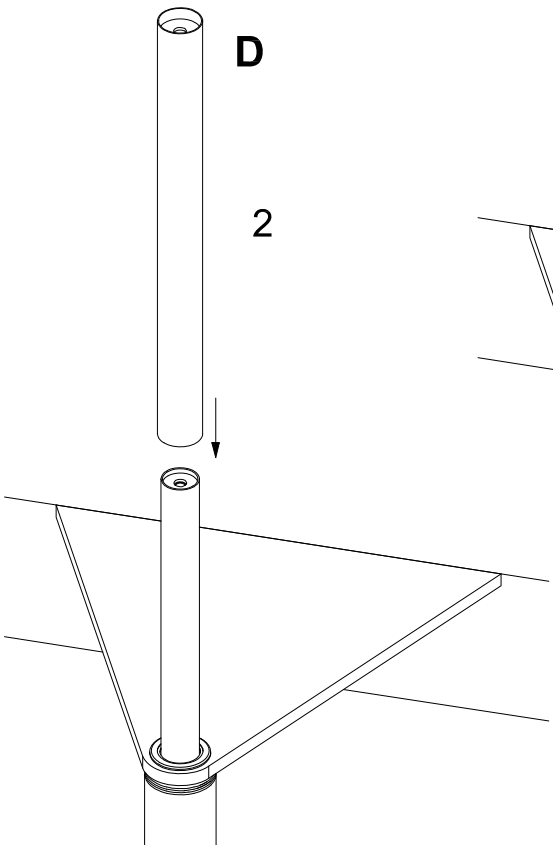
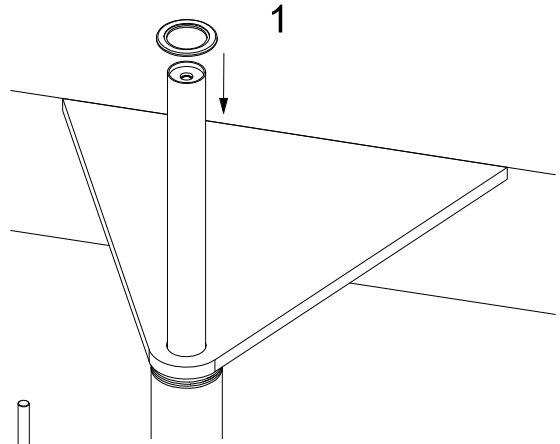
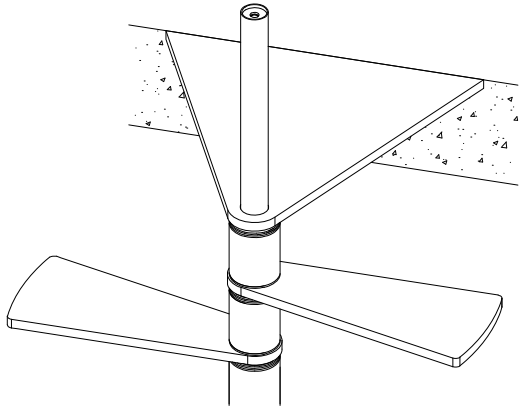

*Non serrare completamente
Do not tighten completely*

ASSEMBLAGGIO RINGHIERA / RAILING ASSEMBLY

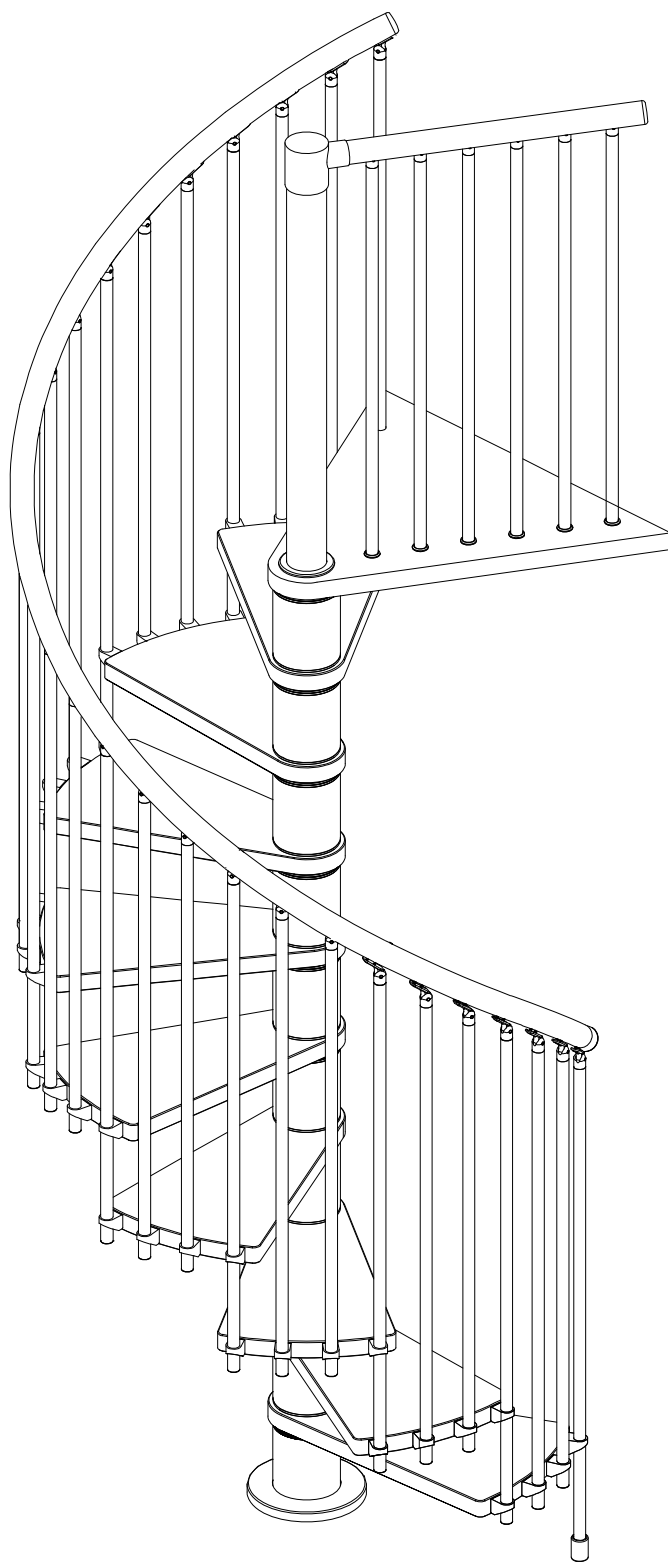

ASSEMBLAGGIO COLLEGAMENTI COLONNA-CORRIMANO / COLUMN-HANDRAIL CONNECTIONS ASSEMBLY

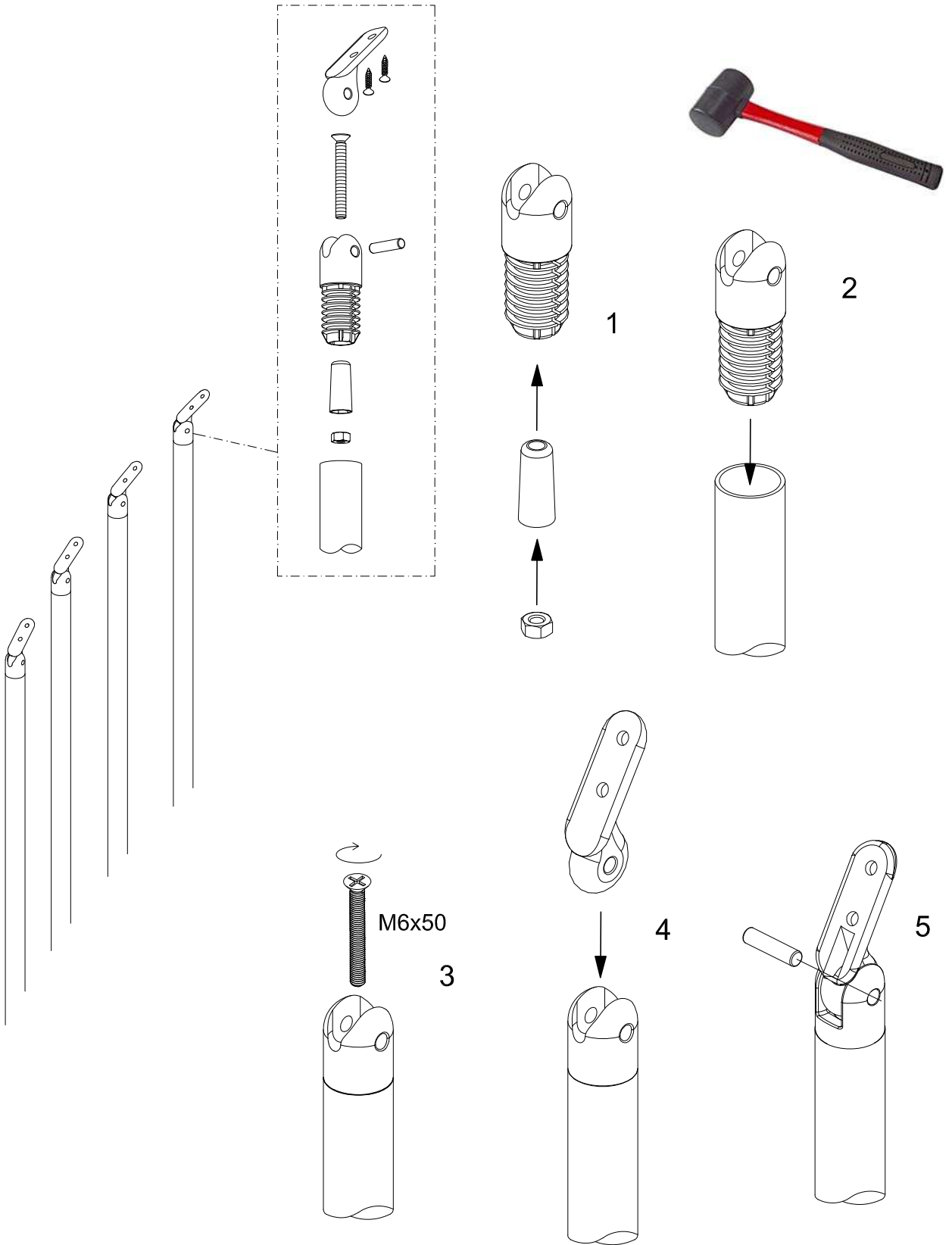

POSIZIONAMENTO DELLE COLONNINE AL VARIARE DELLA ALZATA
 COLUMNS POSITIONING WITH RISE VARIATION

Ø105 / Ø120 / Ø140

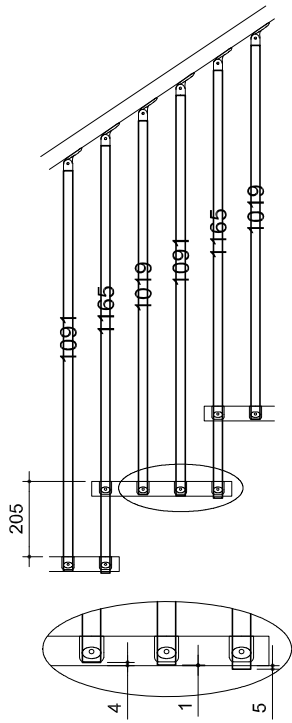

ALZATA / RISE 205

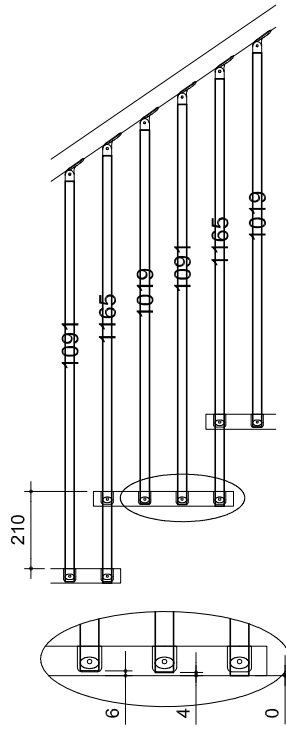

ALZATA / RISE 210

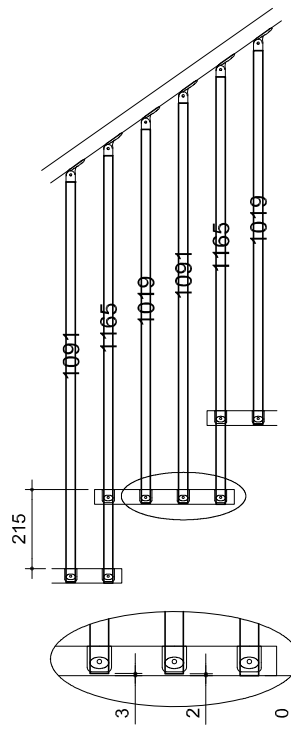

ALZATA / RISE 215

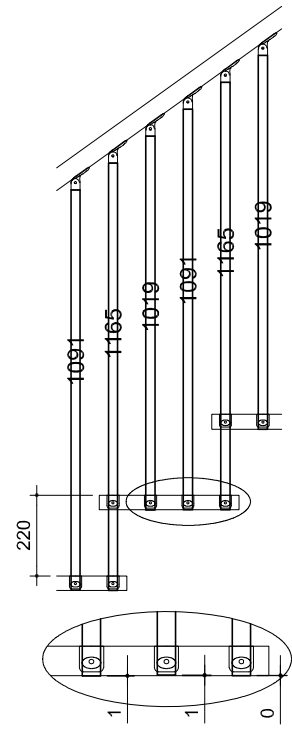

ALZATA / RISE 220

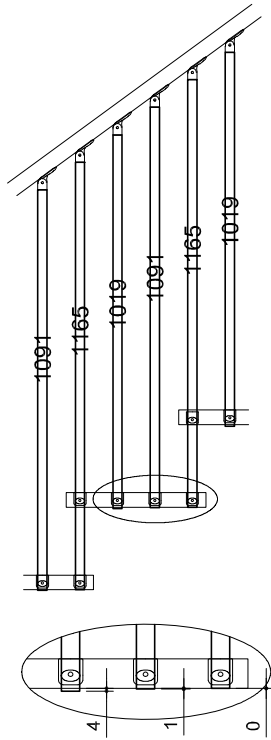

ALZATA / RISE 225

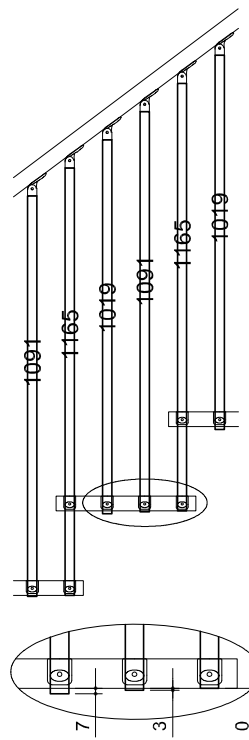

ALZATA / RISE 230

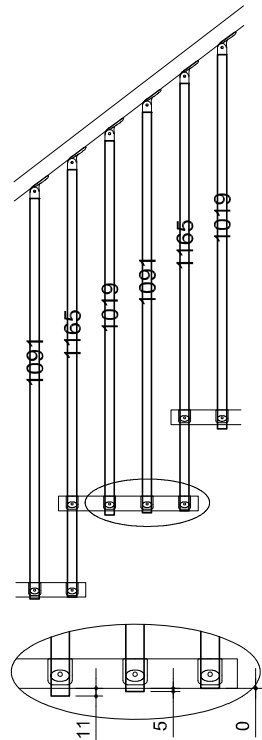

ALZATA / RISE 235

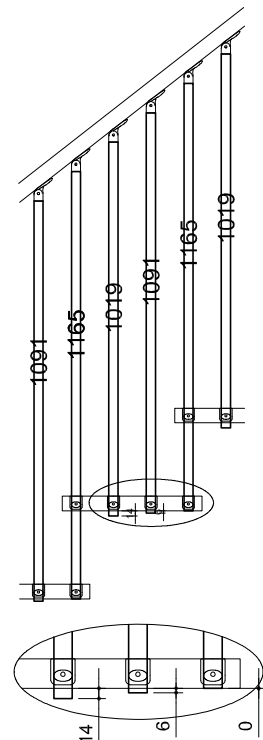

ALZATA / RISE 240

N.B. posizione delle colonnine rispetto al sotto del gradino
 Att. position of the columns with respect to the bottom of the step

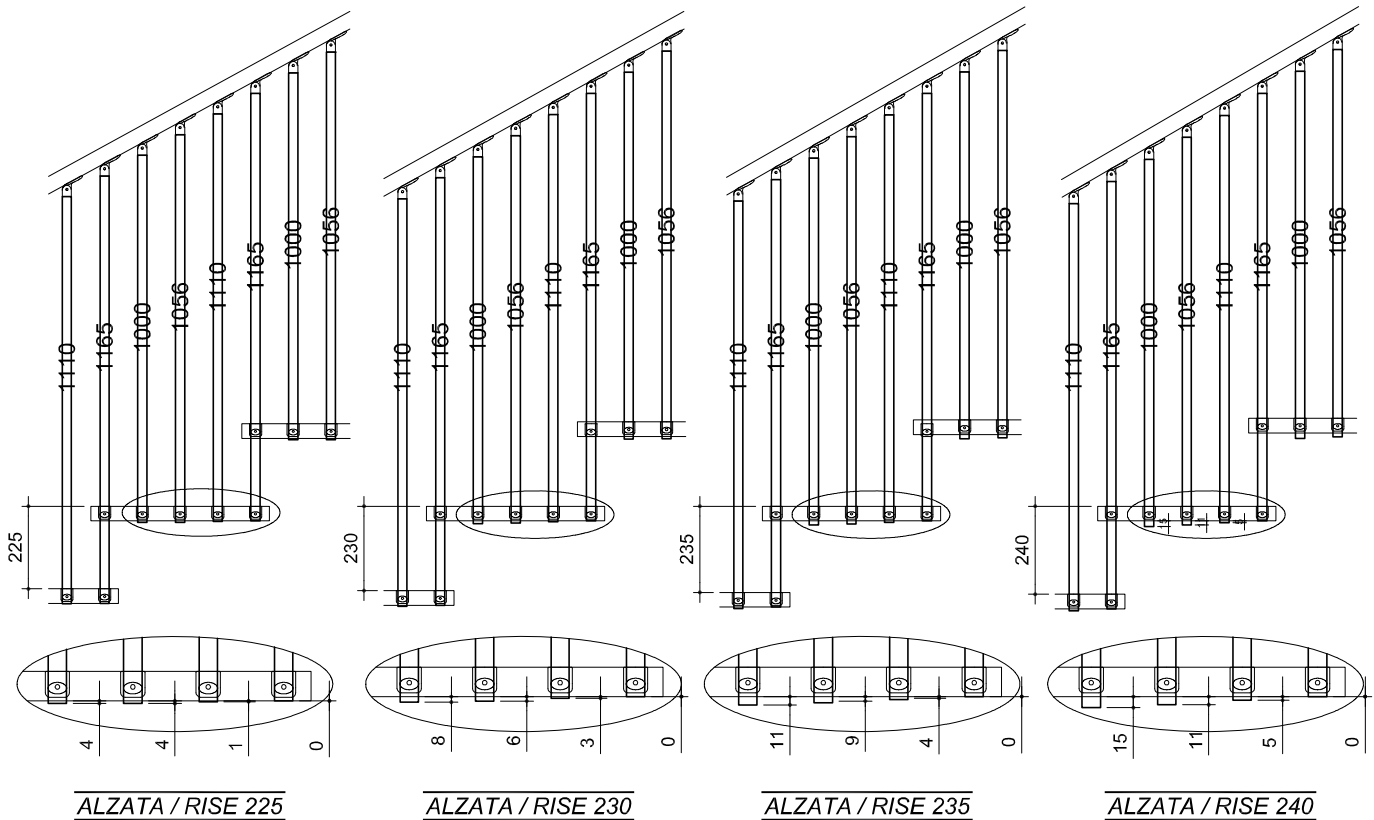
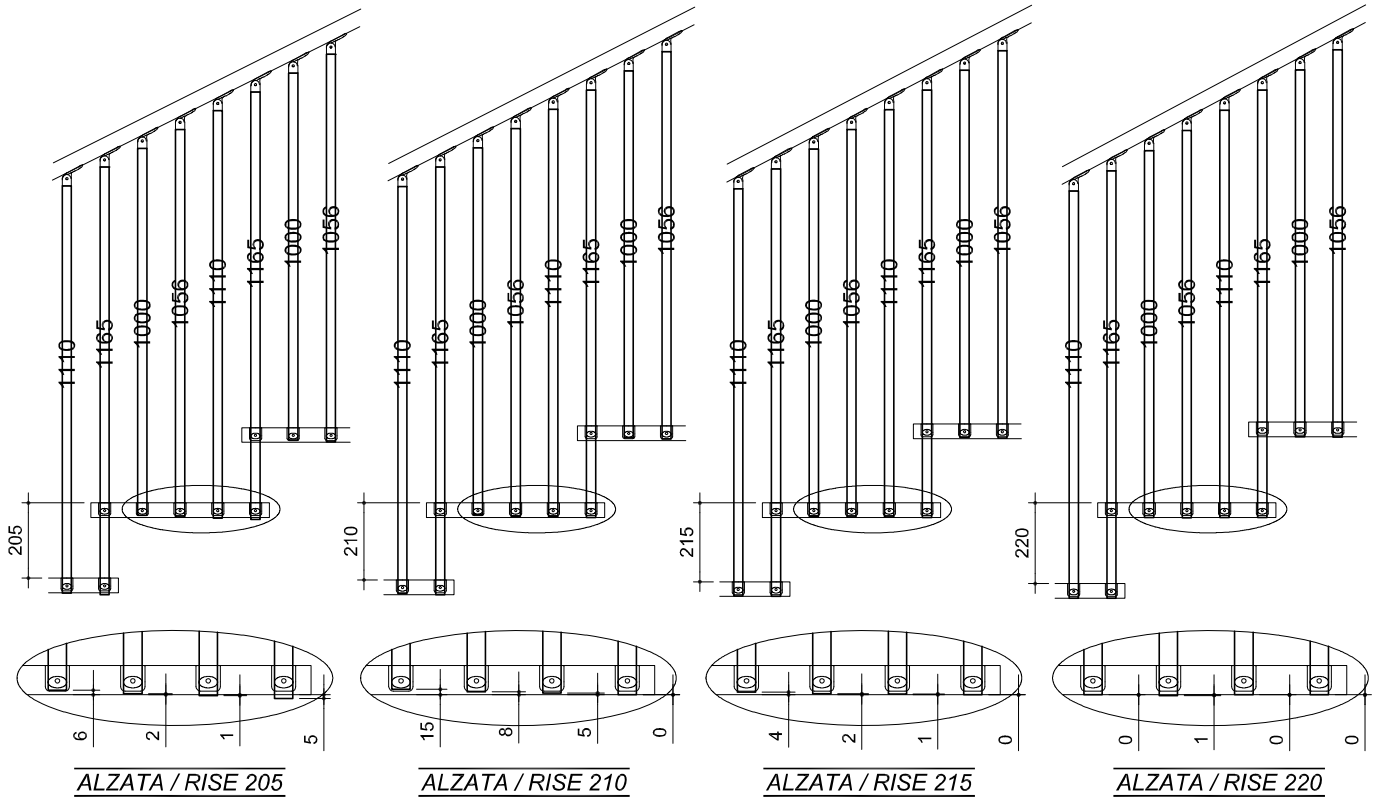

N.B. posizione delle colonnine rispetto al sotto del gradino
 Att. position of the columns with respect to the bottom of the step

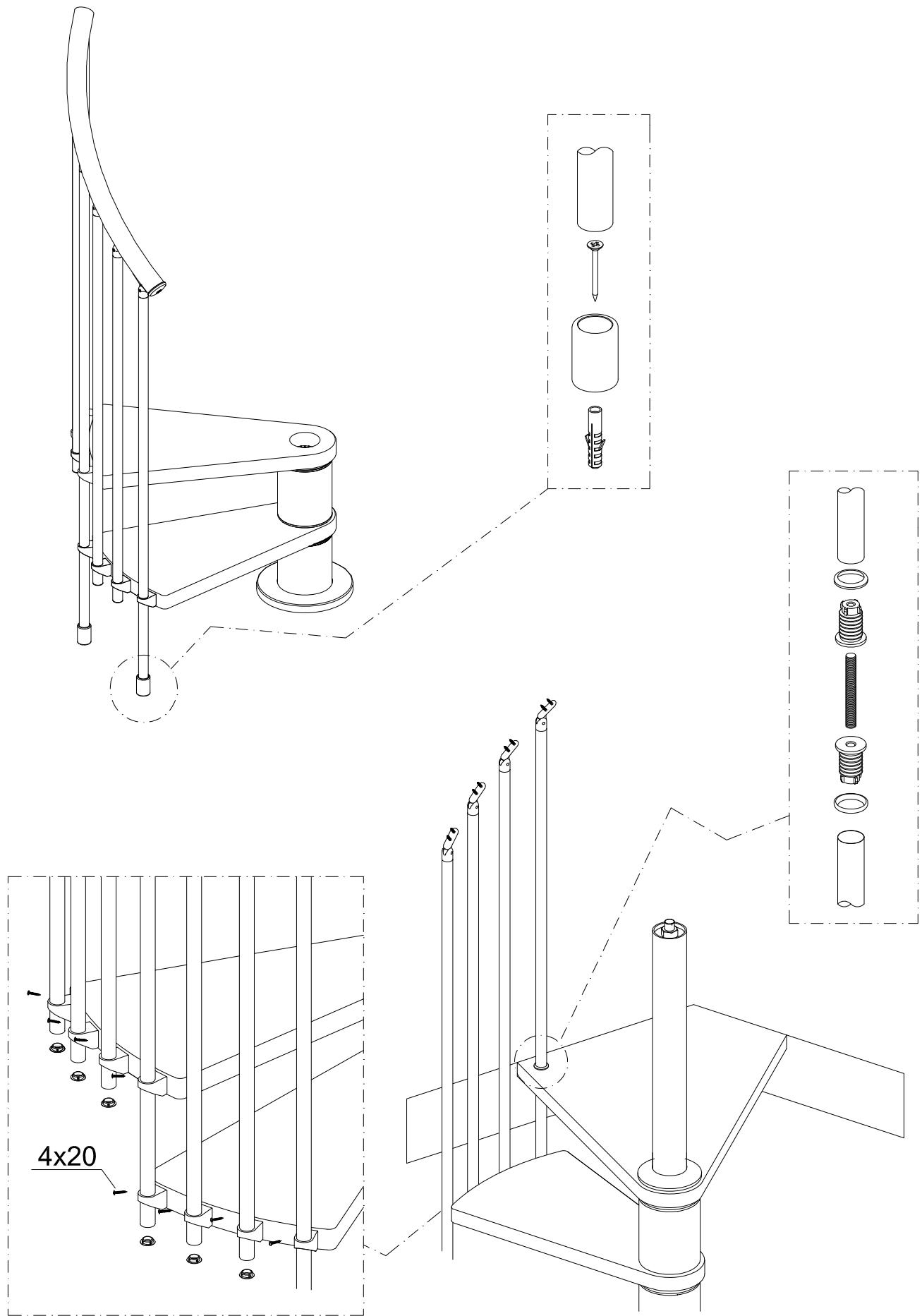

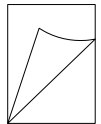
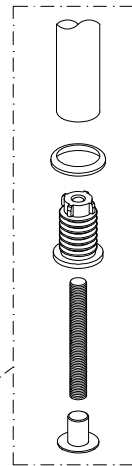
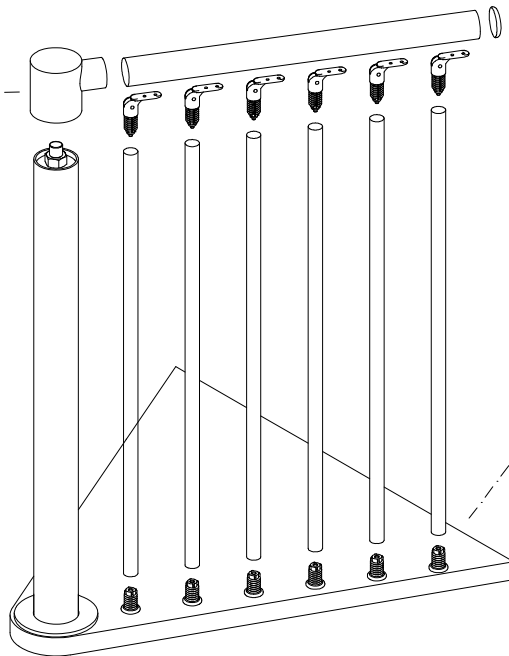
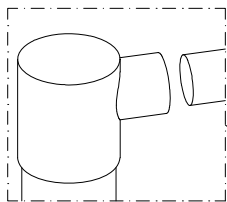
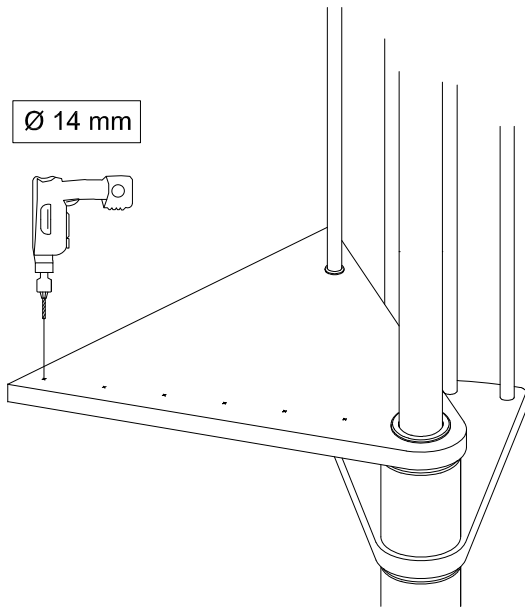
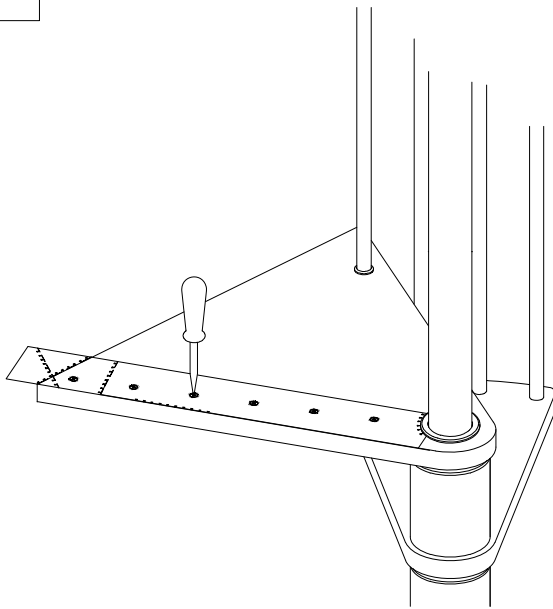
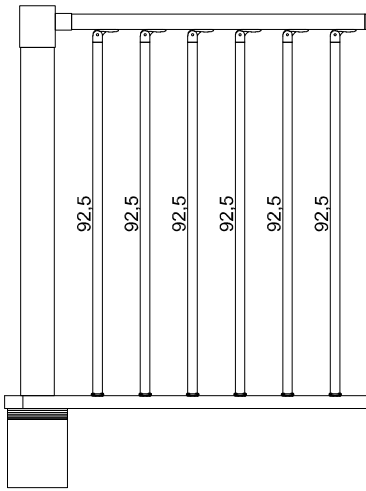

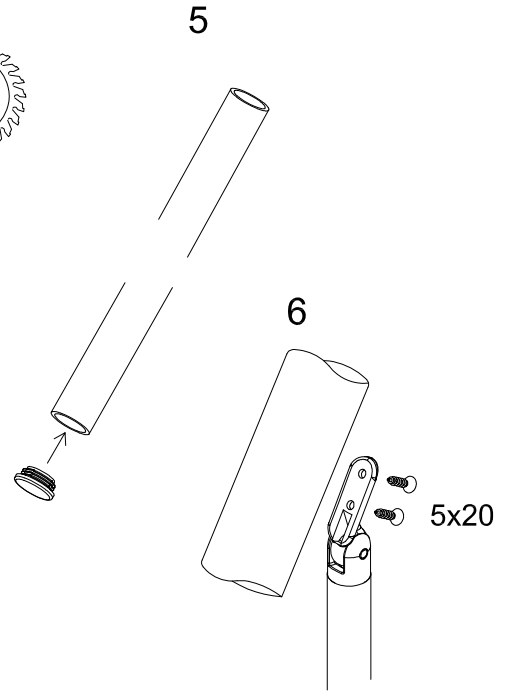
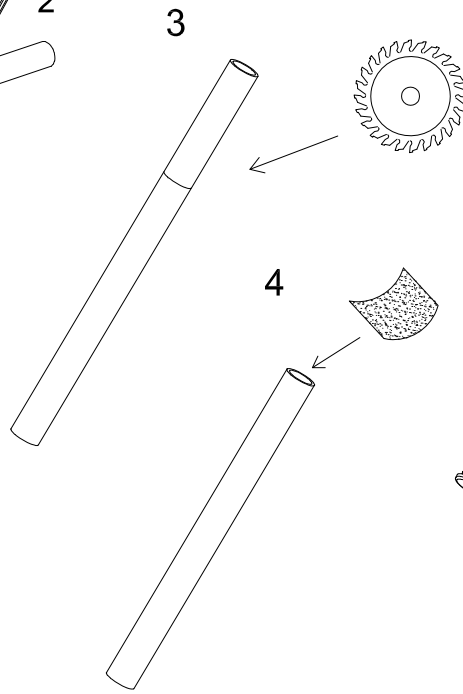
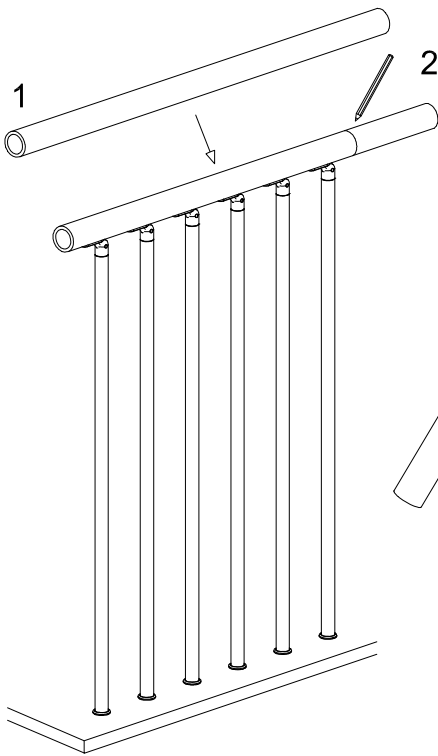
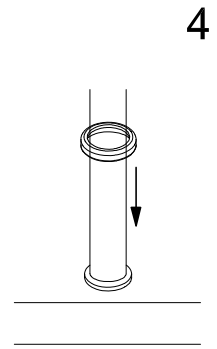
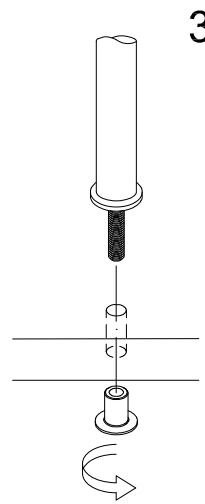
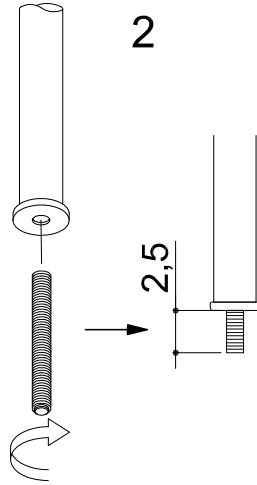
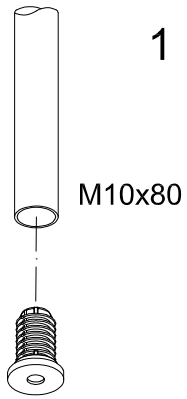
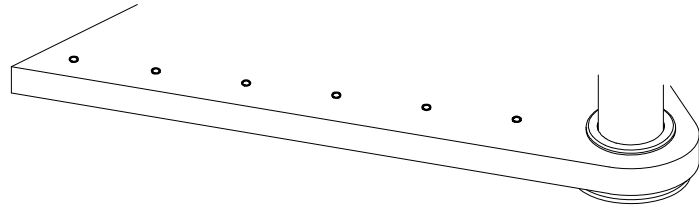

19

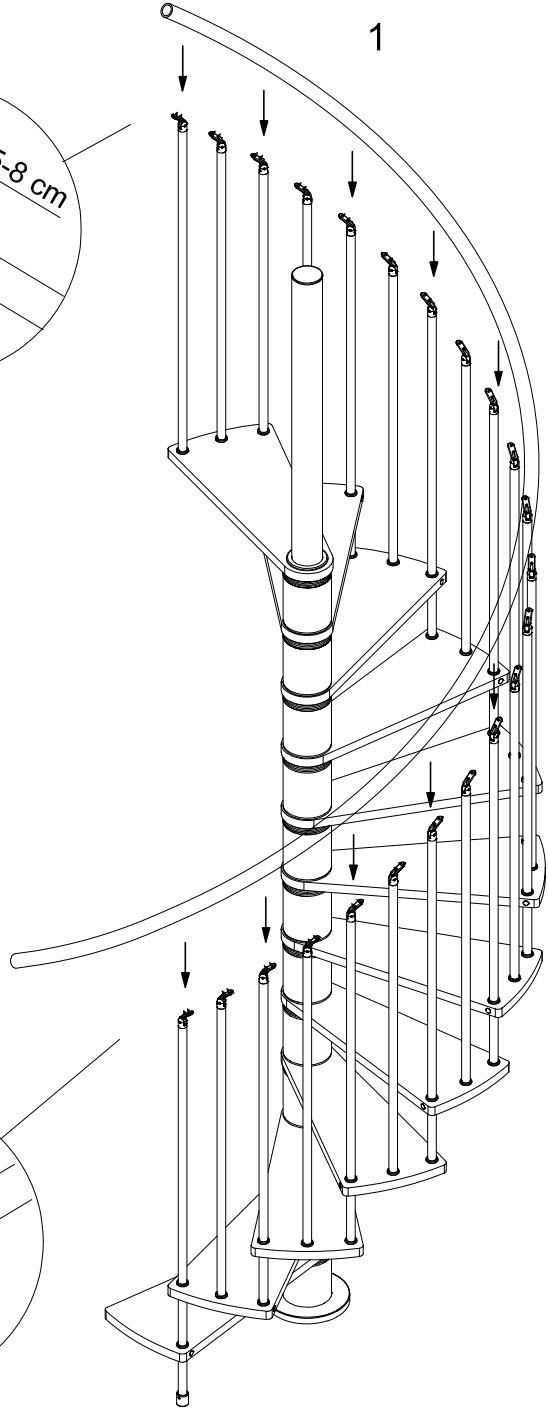
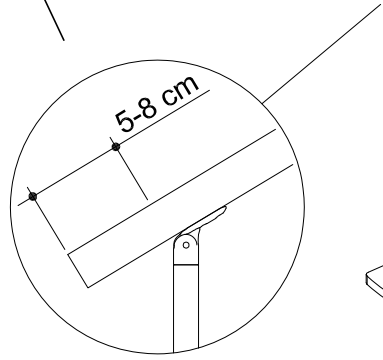
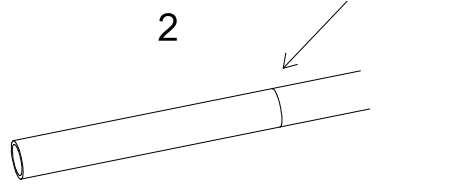
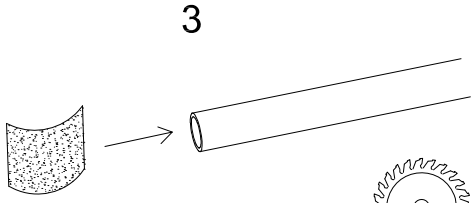
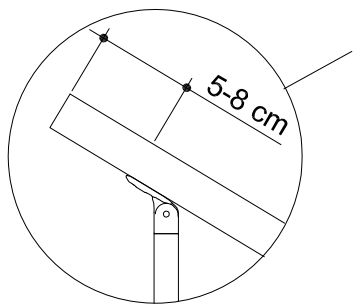
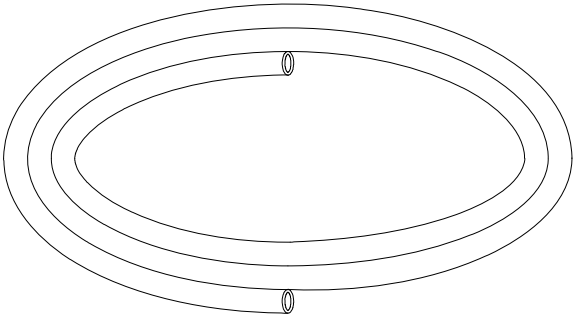

5

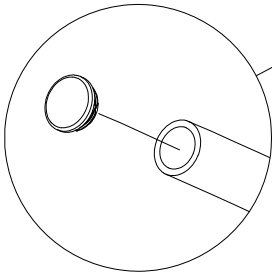

4

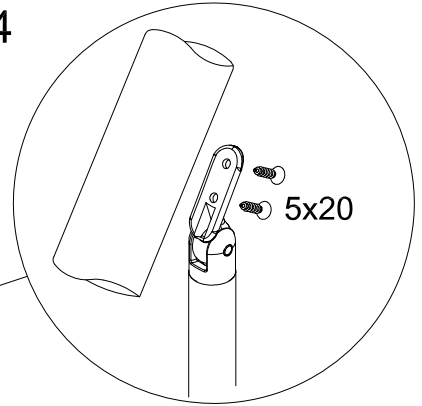

6

